

H-Max™ Series Adjustable Frequency Drive

Installation Manual

Effective September 2011
Supersedes August 2011



Disclaimer of Warranties and Limitation of Liability

The information, recommendations, descriptions, and safety notations in this document are based on Eaton Electrical Inc. and/or Eaton Corporation's ("Eaton") experience and judgment, and may not cover all contingencies. If further information is required, an Eaton sales office should be consulted.

Sale of the product shown in this literature is subject to the terms and conditions outlined in appropriate Eaton selling policies or other contractual agreement between Eaton and the purchaser.

THERE ARE NO UNDERSTANDINGS, AGREEMENTS, WARRANTIES, EXPRESSED OR IMPLIED, INCLUDING WARRANTIES OF FITNESS FOR A PARTICULAR PURPOSE OR MERCHANTABILITY, OTHER THAN THOSE SPECIFICALLY SET OUT IN ANY EXISTING CONTRACT BETWEEN THE PARTIES. ANY SUCH CONTRACT STATES THE ENTIRE OBLIGATION OF EATON. THE CONTENTS OF THIS DOCUMENT SHALL NOT BECOME PART OF OR MODIFY ANY CONTRACT BETWEEN THE PARTIES. In no event will Eaton be responsible to the purchaser or user in contract, in tort (including negligence), strict liability or otherwise for any special, indirect, incidental, or consequential damage or loss whatsoever, including but not limited to damage or loss of use of equipment, plant or power system, cost of capital, loss of power, additional expenses in the use of existing power facilities, or claims against the purchaser or user by its customers resulting from the use of the information, recommendations, and descriptions contained herein.

The information contained in this manual is subject to change without notice.

Cover Photo: H-Max Series Drives

Table of Contents

SAFETY

Before Commencing the Installation	vi
Definitions and Symbols	vii
Hazardous High Voltage	vii
Warnings and Cautions	vii

ENGINEERING

Introduction	1
Electrical Power Network	2
Safety and Switching	4
EMC Measures	5
Motor and Application	6

SYSTEM OVERVIEW

Component Identification	9
Selection Criteria	11
Proper Use	12
Maintenance and Inspection	12
Storage	13
Service and Warranty	13

H-MAX SERIES OVERVIEW

How to Use this Manual	14
Receiving and Inspection	14
Catalog Number Selection	16
Power Ratings and Product Selection	17
Electrical Installation	19

INSTALLATION REQUIREMENTS

Standard Mounting Instructions	20
NEMA Type 1/12 Open Drives (1–250 hp)	21
Power Wiring Selection	22
Cable Routing	26
Control Board	30
EMC Installation	31
Checking the Cable and Motor Insulation	39

APPENDIX A

Technical Data	40
----------------------	----

APPENDIX B

Cable Power and Motor Wiring Guidelines	44
---	----

APPENDIX C

Dimension Drawings	47
--------------------------	----

H-Max Series Adjustable Frequency Drive

List of Figures

Drive System (PDS)	1
AC Power Networks with Grounded Center Point (TN-/TT Networks)	2
EMC Environment and Category	5
Parallel Connection of Several Motors to One Frequency Inverter	6
Example of a Motor Ratings Plate	7
Star and Delta Circuit Types	7
V/Hz-Characteristic Curve	7
Bypass Motor Control (Example)	8
H-Max Series	9
Description of the H-Max	9
Block Diagram, Elements of H-Max Frequency Inverters	10
Selection Criteria	11
Rating Plate	15
Approval Sticker	15
Carton Labels (U.S. and Europe)	15
Mounting Space	20
Input Power and Motor Cable Stripping Lengths	24
Wiring the AFD	25
H-Max Series Adjustable Frequency Drive	29
EMC-Compliant Setup (Example: H-Max)	31
Cable Description	32
Locations of the EMC-Jumpers in Frames FS4 to FS6	33
Three-Phase Input Connection	34
Connection to Power Section	34
Ground Connection	34
Removing the Jumper, FS5 as Example	35
Grounding Bar Location, FS8	35
Removing the EMC Jumper, FS7 and FS8	36
Detaching the DC Grounding Bus Bar from Frame, FS7	36
Molex Connector Placement, FS9	37
Removing the EMC Jumper, FS9	37
Product Modified Sticker	37
FS4 Dimension Drawing	46
FS4 Dimension Drawing Flange Mount	47
FS5 Dimension Drawing	48
FS5 Dimension Drawing Flange Mount	49
FS6 Dimension Drawing	50
FS6 Dimension Drawing Flange Mount	51
FS7 Dimension Drawing	52
FS7 Dimension Drawing Flange Mount	53
FS8 Dimension Drawing IP00	54
FS8 Dimension Drawing IP2154 Flange Mount	55
FS8 Dimension Drawing Flange Mount	56
FS9 Dimension Drawing	57
FS9 Dimension Drawing IP2154	58
FS9 Dimension Drawing Flange Mount	59

List of Tables

Identification on the Residual-Current Circuit-Breakers	4
Assignment of Frequency Inverters to Example Motor Circuit	7
Maintenance Measures and Intervals	12
H-Max Series Open Drives	16
NEMA Type 1/IP21 or NEMA Type 12/IP54	17
NEMA Type 1/IP21 or NEMA Type 12/IP54	18
H-Max Series Adjustable Frequency Drive Option Boards	18
Space Requirements for Mounting the H-Max Series AFD and Airflow	20
Mounting Drive Dimensions	21
Power Connection Tightening Torque	23
Spacing Between Parallel Motor Cables	23
Maximum Cable Length by Frame Size without DV/DT Protected C2 Ratings	23
Input Power and Motor Cable Stripping and Wire Lengths	24
International EMC Protection Cable Requirements	32
H-Max Technical Data	39
Standard I/O Board	41
Relay Board 1	42
Relay Board 2	42
North America Cable and Fuse Sizes—208–240 Vac Ratings	43
North America Cable and Fuse Sizes—380–480 Vac Ratings	44
International Cable and Fuse Sizes 380–480 Vac Ratings	45

Safety



Warning! **Dangerous Electrical Voltage!**

Before Commencing the Installation

- Disconnect the power supply of the device
- Ensure that devices cannot be accidentally restarted
- Verify isolation from the supply
- Earth and short circuit the device
- Cover or enclose any adjacent live components
- Follow the engineering instructions (IL04020001E) for the device concerned
- Only suitably qualified personnel in accordance with EN 50110-1/-2 (VDE 0105 Part 100) may work on this device/system
- Before installation and before touching the device ensure that you are free of electrostatic charge
- The functional earth (FE, PES) must be connected to the protective earth (PE) or the potential equalization. The system installer is responsible for implementing this connection
- Connecting cables and signal lines should be installed so that inductive or capacitive interference does not impair the automation functions
- Install automation devices and related operating elements in such a way that they are well protected against unintentional operation
- Suitable safety hardware and software measures should be implemented for the I/O interface so that an open circuit on the signal side does not result in undefined states in the automation devices
- Ensure a reliable electrical isolation of the extra-low voltage of the 24V supply. Only use power supply units complying with IEC 60364-4-41 (VDE 0100 Part 410) or HD384.4.41 S2
- Deviations of the input voltage from the rated value must not exceed the tolerance limits given in the specifications, otherwise this may cause malfunction and dangerous operation
- Emergency stop devices complying with IEC/EN 60204-1 must be effective in all operating modes of the automation devices. Unlatching the emergency-stop devices must not cause a restart
- Devices that are designed for mounting in housings or control cabinets must only be operated and controlled after they have been installed and with the housing closed. Desktop or portable units must only be operated and controlled in enclosed housings
- Measures should be taken to ensure the proper restart of programs interrupted after a voltage dip or failure. This should not cause dangerous operating states even for a short time. If necessary, emergency-stop devices should be implemented
- Wherever faults in the automation system may cause injury or material damage, external measures must be implemented to ensure a safe operating state in the event of a fault or malfunction (for example, by means of separate limit switches, mechanical interlocks, and so on)
- Depending on their degree of protection, adjustable frequency drives may contain live bright metal parts, moving or rotating components, or hot surfaces during and immediately after operation
- Removal of the required covers, improper installation, or incorrect operation of motor or adjustable frequency drive may cause the failure of the device and may lead to serious injury or damage
- The applicable national accident prevention and safety regulations apply to all work carried out on live adjustable frequency drives
- The electrical installation must be carried out in accordance with the relevant regulations (for example, with regard to cable cross sections, fuses, PE)
- Transport, installation, commissioning, and maintenance work must be carried out only by qualified personnel (IEC 60364, HD 384 and national occupational safety regulations)
- Installations containing adjustable frequency drives must be provided with additional monitoring and protective devices in accordance with the applicable safety regulations. Modifications to the adjustable frequency drives using the operating software are permitted
- All covers and doors must be kept closed during operation
- To reduce hazards for people or equipment, the user must include in the machine design measures that restrict the consequences of a malfunction or failure of the drive (increased motor speed or sudden standstill of motor). These measures include:
 - Other independent devices for monitoring safety-related variables (speed, travel, end positions, and so on)
 - Electrical or non-electrical system-wide measures (electrical or mechanical interlocks)
 - Never touch live parts or cable connections of the adjustable frequency drive after it has been disconnected from the power supply. Due to the charge in the capacitors, these parts may still be live after disconnection. Fit appropriate warning signs

Safety

Definitions and Symbols

 **WARNING**

This symbol indicates high voltage. It calls your attention to items or operations that could be dangerous to you and other persons operating this equipment. Read the message and follow the instructions carefully.



This symbol is the "Safety Alert Symbol." It occurs with either of two signal words: CAUTION or WARNING, as described below.

 **WARNING**

Indicates a potentially hazardous situation which, if not avoided, can result in serious injury or death.

 **CAUTION**

Indicates a potentially hazardous situation which, if not avoided, can result in minor to moderate injury, or serious damage to the product. The situation described in the CAUTION may, if not avoided, lead to serious results. Important safety measures are described in CAUTION (as well as WARNING).

Hazardous High Voltage

 **WARNING**

Motor control equipment and electronic controllers are connected to hazardous line voltages. When servicing drives and electronic controllers, there may be exposed components with housings or protrusions at or above line potential. Extreme care should be taken to protect against shock.

Stand on an insulating pad and make it a habit to use only one hand when checking components. Always work with another person in case an emergency occurs. Disconnect power before checking controllers or performing maintenance. Be sure equipment is properly grounded. Wear safety glasses whenever working on electronic controllers or rotating machinery.

Warnings and Cautions

 **CAUTION**

When selecting the cable cross-section, take the voltage drop under load conditions into account.

The consideration of other standards (for example, VDE 0113 or VDE 0289) is the responsibility of the user.

 **CAUTION**

The specified minimum PE conductor cross-sections (EN 50178, VDE 0160) must be maintained.

 **WARNING**

With frequency inverters, only AC/DC sensitive residual current circuit breakers (RCD type B) are to be used (EN 50178, IEC 755).

 **CAUTION**

Debounced inputs may not be used in the safety circuit diagram.

Residual current circuit breakers (RCD) are only to be installed between the AC power supply network and the frequency inverter.

 **CAUTION**

Debounced inputs may not be used in the safety circuit diagram.

If you are connecting multiple motors on one frequency inverter, you must design the contactors for the individual motors according to utilization category AC-3.

Selecting the motor contactor is done according to the rated operational current of the motor to be connected.

 **CAUTION**

Debounced inputs may not be used in the safety circuit diagram.

A changeover between the frequency inverter and the input supply must take place in a voltage-free state.

 **WARNING**

The frequency inverter outputs (U, V, W) must not be connected to the input voltage (destruction of the device, risk of fire).

 **CAUTION**

Debounced inputs may not be used in the safety circuit diagram.

Switch S1 must switch only when frequency inverter T1 is at zero current.

 **WARNING**

Carry out wiring work only after the frequency inverter has been correctly mounted and secured.

 **WARNING**

Electric shock hazard—risk of injuries!

Carry out wiring work only if the unit is de-energized.

 **CAUTION**

Debounced inputs may not be used in the safety circuit diagram.

Fire hazard!

Only use cables, protective switches, and contactors that feature the indicated permissible nominal current value.

 **CAUTION**

Debounced inputs may not be used in the safety circuit diagram.

Ground contact currents in frequency inverters are greater than 3.5 mA (AC). According to product standard IEC/EN 61800-5-1, an additional equipment grounding conductor must be connected, or the cross-section of the equipment grounding conductor must be at least 0.39 in² (10 mm²).

 **WARNING**

The components in the frequency inverter's power section remain energized up to five (5) minutes after the supply voltage has been switched off (intermediate circuit capacitor discharging time).

Pay attention to hazard warnings!

 
DANGER
5 MIN

 **WARNING**

Do not perform any modifications on the AC drive when it is connected to mains.

 **CAUTION**

Before connecting the AC drive to mains make sure that the EMC protection class settings of the drive are appropriately made.

Engineering

Introduction

This chapter describes the most important features in the energy circuit of a drive system (PDS = Power Drive System) that you should take into consideration in your project planning.

Drive System (PDS)

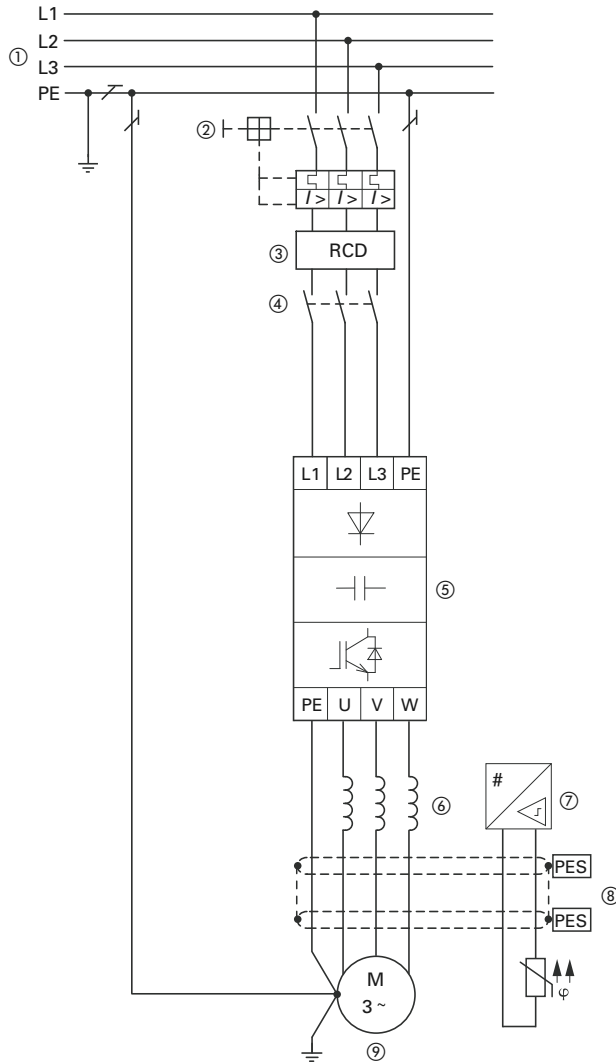

Item Number	Description
1	Network configuration, input voltage, input frequency, interaction with p.f. correction systems
2	Breakers, fuses, and cable cross-sections
3	Protection of persons and domestic animals with residual-current protective devices
4	Input contactor
5	Frequency inverter: mounting, installation; power connection; EMC measures; circuit examples
6	Motor reactor, dv/dt filter, sine-wave filter
7	Motor protection; thermistor
8	Cable lengths, motor cables, shielding (EMC)
9	Motor and application, parallel operation of multiple motors on a frequency inverter, bypass circuit; DC braking

Electrical Power Network

Input Connection and Configuration

The H-Max series frequency inverters can be connected and operated with all control-point grounded AC power networks (see IEC 60364 for more information).

AC Power Networks with Grounded Center Point (TN-/TT Networks)

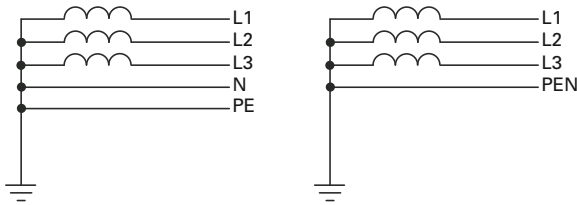

While planning the project, consider a symmetrical distribution to the three external conductors, if multiple frequency inverters with single-phase supplies are to be connected. The total current of all single-phase consumers is not to cause an overload of the neutral conductor (N-conductor).

The connection and operation of frequency inverters to asymmetrically grounded TN networks (phase-grounded Delta network "Grounded Delta", USA) or non-grounded or high-resistance grounded (over 30 ohms) IT networks is only conditionally permissible.

If the H-Max frequency inverters are connected to an asymmetrically grounded network or to an IT network (non-grounded, insulated), the internal interference suppression filter must be disconnected (unscrew the screw marked EMC, see "Installation in IT System" on **Page 33**). The required filtering for electromagnetic compatibility (EMC) is then no longer present.

Measures for electromagnetic compatibility are mandatory in a drive system in order to meet the legal requirements for EMC and low voltage regulations.

Good grounding measures are a prerequisite for the effective insert of further measures such as shielding or filters. Without respective grounding measures, further steps are superfluous.

Input Voltage and Frequency

The standardized input voltages (IEC 60038, VDE017-1) for energy suppliers (EVU) guarantee the following conditions at the transition points:

- Deviation from the rated value of voltage: maximum $\pm 10\%$
- Deviation in voltage phase balance: maximum $\pm 3\%$
- Deviation from rated value of the frequency: maximum $\pm 4\%$

The broad tolerance band of the H-Max frequency inverter considers the rated value for European as (EU: $U_{LN} = 230V/400V$, 50 Hz) and American as (USA: $U_{LN} = 240V/480V$, 60 Hz) standard voltages:

- 230V, 50 Hz (EU) and 240V, 60 Hz (USA) at HMX32
- 400V, 50 Hz (EU) and 480V, 60 Hz (USA) at HMX34_

For the bottom voltage value, the permitted voltage drop of 4% in the consumer circuits is also taken into account, therefore a total of $U_{LN} - 14\%$.

- 200V device class (HMX32):
208V -10% to 240V $+10\%$ (188V -0% to 264V $+0\%$)
- 400V device class (HMX34):
380V -10% to 480V $+10\%$ (342V -0% to 528V $+0\%$)

The permitted frequency range is 50/60 Hz (48 Hz -0% -66 Hz $+0\%$).

Voltage Balance

Because of the uneven loading on the conductor, and with the direct connection of greater power ratings, deviations from the ideal voltage form and asymmetrical voltages can be caused in three-phase AC power networks. These asymmetric divergences in the input voltage can lead to different loading of the diodes in input rectifiers with three-phase supplied frequency inverters, and as a result, an advance failure of this diode.

In the project planning for the connection of three-phase supplied frequency inverters (HMX32, HMX34), consider only AC power networks that handle permitted asymmetric divergences in the input voltage $\leq +3\%$.

If this condition is not fulfilled, or symmetry at the connection location is not known, the use of an assigned main choke is recommended.

Total Harmonic Distortion (THD)

The THD (Total Harmonic Distortion) is a measurement for the occurring harmonic distortion of the sinusoidal oscillation (input power side) input variables with the frequency inverter. It is given in percent of the total value.

$$K = \sqrt{\frac{U_2^2 + U_3^2 + U_4^2 + \dots + U_n^2}{U_1^2 + U_2^2 + U_3^2 + U_4^2 + \dots + U_n^2}} \cdot 100\%$$

U_1 = fundamental component

THD $k = 0.1 \rightarrow K = 10\% \sim -20$ dB (THD suppression)

$$\text{THD} = \frac{\sqrt{U_2^2 + U_3^2 + U_4^2 + \dots + U_n^2}}{U_1}$$

With H-Max series frequency inverters, the permitted value for the total harmonic distortion THD is $>120\%$.

Idle Power Compensation Devices

Compensation on the power supply side is not required for H-Max series frequency inverters. From the AC power supply network, they take on very little reactive power of the fundamental harmonics ($\cos \varphi \sim 0.98$).

In the AC power networks with non-choked idle current compensation devices, current deviations can enable parallel resonance and undefinable circumstances.

In the project planning for the connection of frequency inverters to AC power networks with undefined circumstances, consider using main chokes.

Safety and Switching

Fuses and Cable Cross-Sections

The fuses and wire cross-sections allocated for power-side connections depend on the rated input current I_{LN} of the frequency inverter (without input reactor).

 **CAUTION**

When selecting the cable cross-section, take the voltage drop under load conditions into account.

The consideration of other standards (for example, VDE 0113 or VDE 0289) is the responsibility of the user.

The national and regional standards (for example VDE 0113, EN 60204) must be observed and the necessary approvals (for example UL) at the site of installation must be fulfilled.

When the device is operated in a UL-approved system, use only UL-approved breakers, fuses, fuse bases, and cables.

The leakage currents to ground (to EN 50178) are greater than 3.5 mA. The connection terminals marked PE and the housing must be connected with the ground circuit.

 **CAUTION**

The specified minimum PE conductor cross-sections (EN 50178, VDE 0160) must be maintained.

Choose the cross-section of the PE conductor in the motor lines at least as large as the cross-section of the phase lines (U, V, W).

Cables and Fuses

The cross-sections of the cables and line protection fuses used must correspond with local standards.

For an installation in accordance with UL guidelines, the fuses and copper cable that are UL-approved and have a heat-resistance of 167° to 194°F (75° to 90°C) are to be used.

Use power cables with insulation according to the specified input voltages for the permanent installation. A shielded cable is not required on the input side.

A completely (360°) shielded low impedance cable is required on the motor side. The length of the motor cable depends on the RFI class and must not exceed 500 ft (153m) without additional filtering.

Residual-Current Device (RCD)

RCD (Residual Current Device): Residual current device, residual current circuit breaker (FI circuit breaker).

Residual current circuit breakers protect persons and animals from the existence (not the origination) of impermissibly high contact voltages. They prevent dangerous, and in some cases deadly injuries caused by electrical accidents, and also serve as fire prevention.

 **WARNING**

With frequency inverters, only AC/DC sensitive residual current circuit breakers (RCD type B) are to be used (EN 50178, IEC 755).

Identification on the Residual-Current Circuit-Breakers

AC/DC sensitive
(RCD, type B)



Frequency inverters work internally with rectified AC currents. If an error occurs, the DC currents can block a type A RCD circuit breaker from triggering and therefore disable the protective functionality.

 **CAUTION**

Debounced inputs may not be used in the safety circuit diagram.

Residual current circuit breakers (RCD) are only to be installed between the AC power supply network and the frequency inverter.

Safety-relevant leakage currents can occur while handling and when operating the frequency inverter, if the frequency inverter is not grounded (because of a fault).

Leakage currents to ground are mainly caused by foreign capacities with frequency inverters; between the motor phases and the shielding of the motor cable and via the Y-capacitors of the noise filter. The size of the leakage current is mainly dependent upon the:

- length of the motor cable
- shielding of the motor cable
- height of the pulse frequency (switching frequency of the inverter)
- design of the noise filter
- grounding measures at the site of the motor

The leakage current to ground is greater than 3.5 mA with a frequency inverter. Based on the requirements of EN 50178, an increased ground (PE) has to be connected. The cable cross-section must be at least 10 mm² or consist of two separately connected ground cables.

Residual current circuit breakers must be suitable for:

- the protection of installations with DC current component in case of fault scenario (RCD type B)
- high leakage currents (300 mA)
- brief discharges of pulse current spikes

Input Contactor

The input contactor enables an operational switching on and off of the supply voltage for the frequency inverter, and switching off in case of a fault.

The input contactor is designed based on the input current (I_{LN}) of the frequency inverter and the utilization category AC-1 (IEC 60947). Input contactors and the assignment to H-Max frequency inverters are explained in the appendix.

While planning the project, make sure that inching operation is not done via the input contactor of the frequency inverter on frequency-controlled drives, but through a controller input of the frequency inverter.

The maximum permitted operating frequency of the input voltage with the H-Max frequency inverter is one time per minute (normal operation).

EMC Measures

Electrical components in a system (machine) have a reciprocal effect on each other. Each device not only emits interference but is also affected by it. The interference can be produced by galvanic, capacitive, and/or inductive sources, or by electromagnetic radiation. In practice, the limit between line-conducted interference and emitted interference is around 30 MHz. Above 30 MHz, cables and conductors act like antennas that radiate electromagnetic waves.

Electromagnetic compatibility (EMC) for frequency controlled drives (variable speed drives) is implemented in accordance with product standard IEC/EN 61800-3. This includes the complete power drive system (PDS), from the input supply to the motor, including all components, as well as cables (see figure on **Page 1**). This type of drive system can consist of several individual drives.

The generic standards of the individual components in a PDS compliant with IEC/EN 61800-3 do not apply. These component manufacturers, however, must offer solutions that ensure standards-compliant use.

In Europe, maintaining the EMC guidelines is mandatory.

A declaration of conformity (CE) always refers to a "typical" power drive system (PDS). The responsibility to comply with the legally stipulated limit values and thus the provision of electromagnetic compatibility is ultimately the responsibility of the end user or system operator. This operator must also take measures to minimize or remove emission in the environment concerned (see figure below). He must also use means to increase the interference immunity of the devices of the system.

With their high interference immunity up to category C2, H-Max frequency inverters are ideal for use in commercial networks (1st environment).

EMC Environment and Category

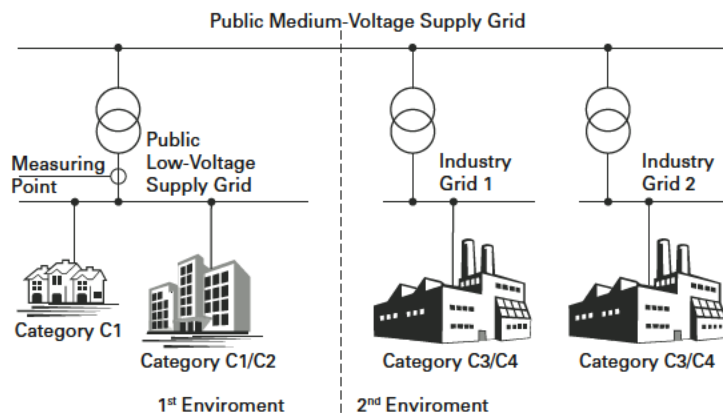

Motor and Application

Motor Selection

General recommendations for motor selection:

- Use three-phase powered asynchronous motors with short-circuit rotors and surface cooling, also called asynchronous motors or standard motors for the frequency-controlled drive system (PDS). Other specifications such as external rotor motors, slip-ring motors, reluctance motors, synchronous or servo motors can also be run with a frequency inverter, but normally require additional planning and discussion with the motor manufacturer
- Use only motors with at least heat class F (311°F [155°C] maximum steady state temperature)
- Four-pole motors are preferred (synchronous speed: 1500 min⁻¹ at 50 Hz or 1800 min⁻¹ at 60 Hz)
- Take the operating conditions into account for S1 operation (IEC 60034-1)
- When operating multiple motors in parallel on one frequency inverter, the motor output should not be more than three power classes apart
- Ensure that the motor is not overdimensioned. If a motor in speed control mode is underdimensioned, the motor rating must only be one rating level lower

Connecting Motors in Parallel

The H-Max frequency inverters allow parallel operation of several motors using multi-pump application control mode:

- Multi-pump application: several motors with the same or different rated operational data. The sum of all motor currents must be less than the frequency inverter's rated operational current
- Multi-pump application: parallel control of several motors. The sum of the motor currents plus the motors' inrush currents must be less than the frequency inverter's rated operational current

Parallel operation at different motor speeds can be implemented only by changing the number of pole pairs and/or changing the motor's transmission ratio.

CAUTION

Debounced inputs may not be used in the safety circuit diagram.

If you are connecting multiple motors on one frequency inverter, you must design the contactors for the individual motors according to utilization category AC-3.

Selecting the motor contactor is done according to the rated operational current of the motor to be connected.

Parallel Connection of Several Motors to One Frequency Inverter

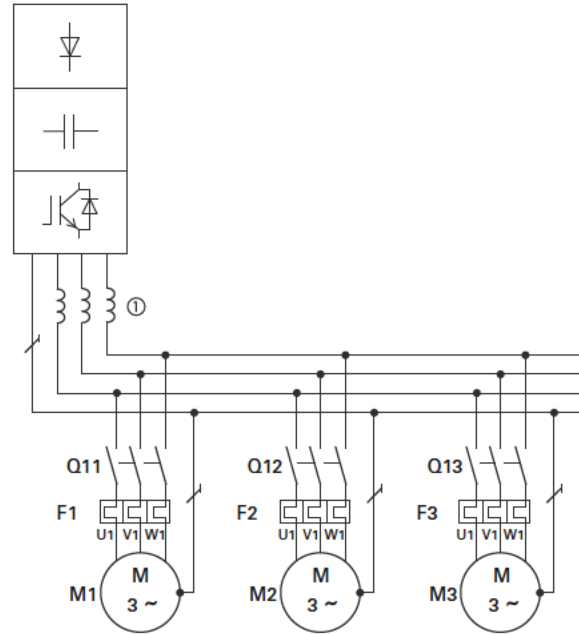

Connecting motors in parallel reduces the load resistance at the frequency inverter output. The total stator inductance is lower and the leakage capacity of the lines greater. As a result, the current distortion is greater than in a single-motor circuit. To reduce the current distortion, you should use motor reactors (see **1** in figure above) in the output of the frequency inverter.

The current consumption of all motors connected in parallel must not exceed the frequency inverter's rated output current I_{2N}.

Electronic motor protection cannot be used when operating the frequency inverter with several parallel connected motors. You must, however, protect each motor with thermistors and/or overload relays.

The use of a motor protective circuit breaker at the frequency inverter's output can lead to nuisance tripping.

Motor and Circuit Type

The motor's stator winding can be connected in a star or delta configuration, in accordance with the rated operational data on the nameplate.

Example of a Motor Ratings Plate

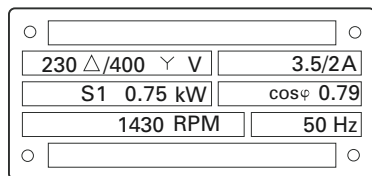

Star and Delta Circuit Types

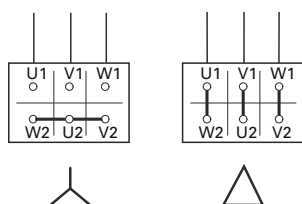

The three-phase motor with the rating plate based on the figure shown above, can be run in a star or delta connection. The operational characteristic curve is determined by the ratio of motor voltage and motor frequency, in this case.

87-Hz Characteristic Curve

In the delta circuit with 400V and 87 Hz, the motor shown in the figure above was released with three times-fold output (~1.3 kW).

Because of the higher thermal loading, using only the next higher motor output according to the list (1.1 kW) is recommended. The motor (in this example) therefore still has 1.47-fold higher output compared with the listed output (0.75 kW).

With the 87-Hz characteristic curve, the motor also works in the range from 50 to 87 Hz with an unattenuated field. The pull-out torque remains at the same level as in input operation with 50 Hz.

The heat class of the motor must be at least F in 87-Hz operation.

V/Hz-Characteristic Curve

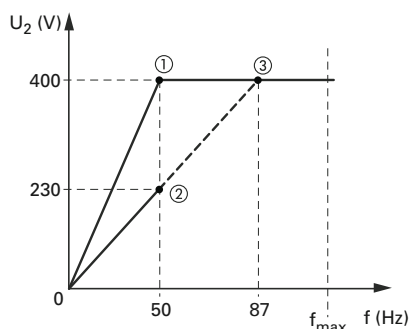

The following table shows the allocation of possible frequency inverters depending on the input voltage and the type of circuit.

Assignment of Frequency Inverters to Example Motor Circuit (See Figure Above)

Frequency Inverters	HMX32AG3D7	HMX34AG3D4	HMX34AG4D8
Rated operational current	3.7A	3.4A	4.8A
Input voltage	3 AC 230V	3 AC 400V	3 AC 400V
Motor circuit	Delta	Star	Delta
V/Hz-characteristic curve	②	①	③
Motor current	3.5A	2.0A	3.5A
Motor voltage (ratings plate)	230V	400V	230V
Motor speed	1430 min ⁻¹	1430 min ⁻¹	2474 min ⁻¹ ④
Motor frequency	50 Hz	50 Hz	87 Hz ④

Notes

- ① Star connection: 400V, 50 Hz.
- ② Delta connection: 230V, 50 Hz.
- ③ Delta connection: 400V, 87 Hz.
- ④ Note the permitted limit values of the motor.

Bypass Operation

If you want to have the option of operating the motor with the frequency inverter or directly from the input supply, the input branches must be interlocked mechanically.

⚠ CAUTION

Debounced inputs may not be used in the safety circuit diagram.

A changeover between the frequency inverter and the input supply must take place in a voltage-free state.

⚠ WARNING

The frequency inverter outputs (U, V, W) must not be connected to the input voltage (destruction of the device, risk of fire).

Bypass Motor Control (Example)

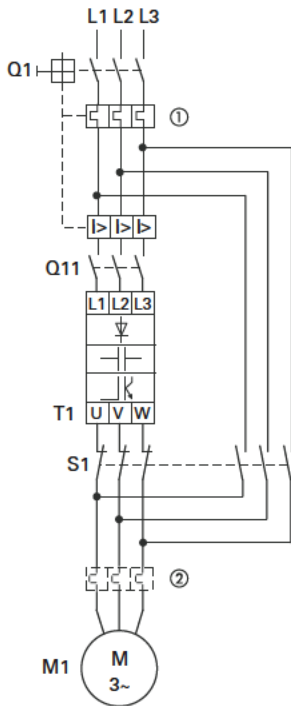

Item Number	Description
1	Input/bypass contactor
2	Output contactor

⚠ CAUTION

Debounced inputs may not be used in the safety circuit diagram.

Switch S1 must switch only when frequency inverter T1 is at zero current.

Contactors and switches (S1) in the frequency inverter output and for the direct start must be designed based on utilization category AC-3 for the rated operational current of the motor.

Connecting EX Motors

Note the following when connecting explosion-protected motors:

- The frequency inverter must be installed outside the EX area
- Note the branch- and country-specific standards for explosion-protected areas (ATEX 100a)
- Note the standards and information of the motor manufacturer regarding operation on frequency inverters—for example, if motor reactors (du/dt-limiting) or sinus filters are specified
- Temperature monitors in the motor windings (thermistor, thermo-Click) are not to be connected directly to frequency inverters but must be connected via an approved trigger apparatus for EX areas

System Overview

Component Identification

H-Max Series

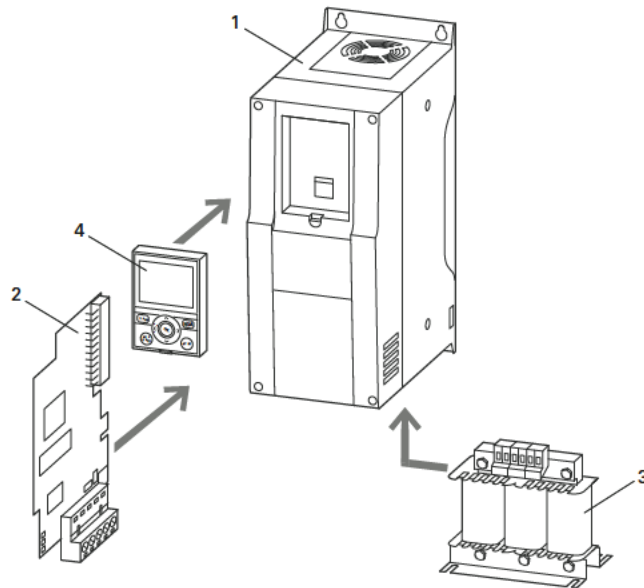

Item Number	Description
1	Frequency inverter HMX- <u> </u>
2	I/O option boards
3	Motor reactor DEX-LM3, sinusoidal filter SFB400
4	Keypad

Description of the H-Max

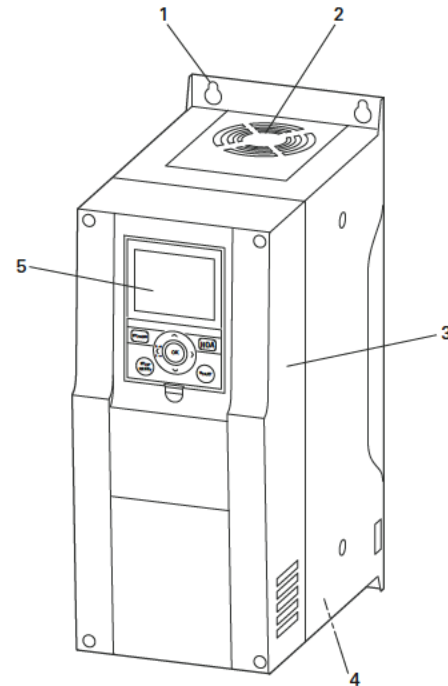

Item Number	Description
1	Mounting holes
2	Device fan
3	Front cover
4	Power terminals
5	Keypad with display

Features

The H-Max frequency inverter converts the voltage and frequency of an existing AC network into a DC voltage. This DC voltage is used to generate a three-phase AC voltage with adjustable frequency and assigned amplitude values for the variable speed control of three-phase asynchronous motors.

Block Diagram, Elements of H-Max Frequency Inverters

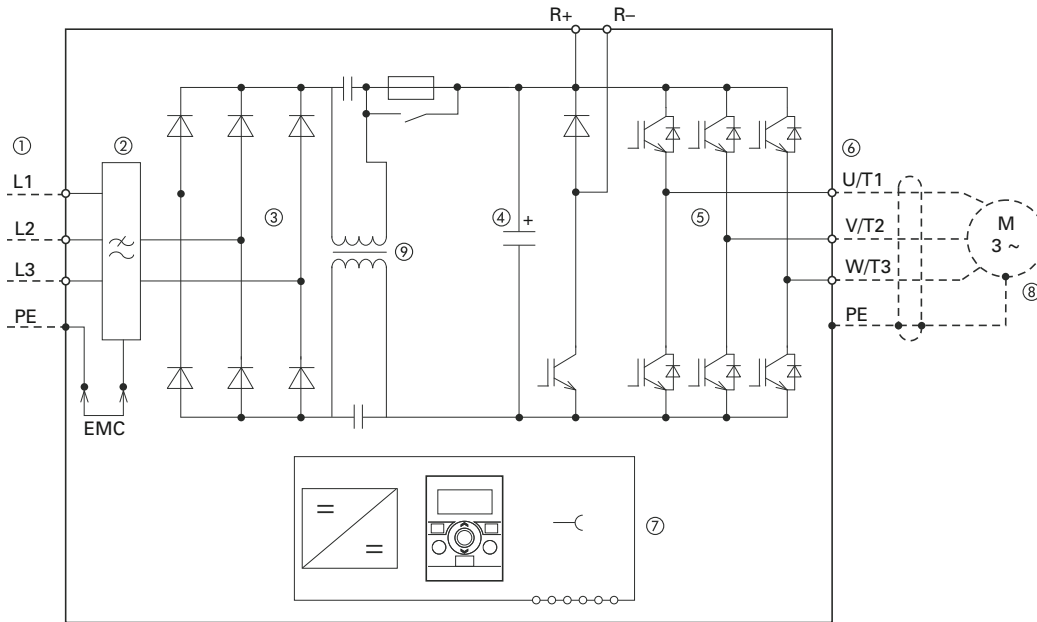

Item Number	Description
1	Supply L1, L2/N, L3, PE, input supply voltage $U_{LN} = U_g$ at 50/60 Hz: HMX32: 200V class, three-phase input connection (3 AC 230V/240V) HMX34: 400V class, three-phase input connection (3 AC 400V/480V)
2	Internal interference suppression filter, category C2 to IEC/EN 61800-3 EMC-connection of internal interference suppression filter to PE
3	Rectifier bridge, converts the AC voltage of the electrical network into DC voltage
4	DC link with charging resistor, capacitor and switching mode power supply unit (SMPS = Switching Mode Power Supply): DC link voltage U_{DC} with three-phase input connection (3 AC): $U_{DC} = 1.41 \times U_{LN}$
5	Inverter. The IGBT based inverter converts the DC voltage of the DC link (U_{DC}) into a three-phase AC voltage (U_2) with variable amplitude and frequency (f_2). Sinusoidal pulse width modulation (PWM) with V/f control can be switched to speed control with slip compensation
6	Motor connection U/T1, V/T2, W/T3 with output voltage U_2 (0–100% U_g) and output frequency f_2 (0–320 Hz) output current (I_2): HMX32: 3.7–310A HMX34: 3.4–310A 100% at an ambient temperature of 104°F (40°C) with an overload capacity of 110% for 60s every 600s and a starting current of 200% for 2s every 20s
7	Keypad with control buttons, graphic display, control voltage, control signal terminals, microswitches, and interface for the PC interface module (option)
8	Three-phase asynchronous motor, variable speed control of three-phase asynchronous motor for assigned motor shaft power values (P_2): HMX32: 0.55–90 kW (230V, 50 Hz) or 0.75–125 hp (230V, 60 Hz) HMX34: 1.1–160 kW (400V, 50 Hz) or 1.5–250 hp (460V, 60 Hz)
9	DC link—chokes, to minimize current harmonics

Selection Criteria

The frequency inverter **[3]** is selected according to the supply voltage U_{LN} of the input supply **[1]** and the rated current of the assigned motor **[2]**. The circuit type (Δ/Y) of the motor must be selected according to the supply voltage **[1]**. The rated output current I_e of the frequency inverter must be greater than/equal to the rated motor current.

Selection Criteria

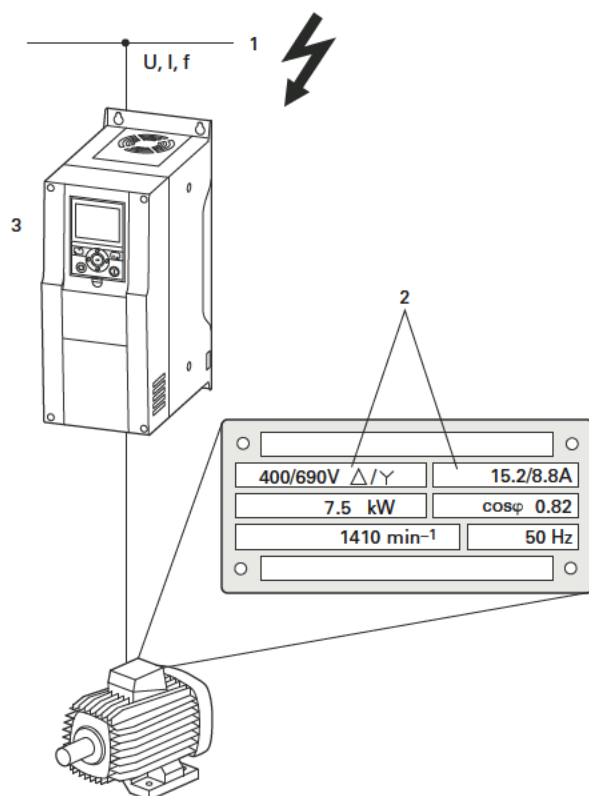

When selecting the drive, the following criteria must be known:

- Type of motor (three-phase asynchronous motor)
- Input voltage = rated operating voltage of the motor (for example, 3 AC~400V)
- Rated motor current (guide value, dependent on the circuit type and the supply voltage)
- Load torque (quadratic, constant)
- Starting torque
- Ambient temperature (rated value 122°F [50°C])

When connecting multiple motors in parallel to the output of a frequency inverter, the motor currents are added geometrically—separated by effective and idle current components. When you select a frequency inverter, make sure that it can supply the total resulting current. If necessary, for dampening and compensating the deviating current values, motor reactors or sinusoidal filters must be connected between the frequency inverter and the motor.

The parallel connection of multiple motors in the output of the frequency inverter is only permitted with V/Hz-characteristic curve control.

If you connect a motor to an operational frequency inverter, the motor draws a multiple of its rated operational current. When you select a frequency inverter, make sure that the starting current plus the sum of the currents of the running motors will not exceed the rated output current of the frequency inverter.

Switching in the output of the frequency inverter is only permitted with V/Hz-characteristic curve control.

System Overview

Proper Use

The H-Max frequency inverters are not domestic appliances. They are designed only for use as HVAC or pumping system components.

The H-Max frequency inverters are electrical apparatus for controlling variable speed drives with three-phase motors. They are designed for installation in machines or for use in combination with other components within a machine or system.

After installation in a machine, the frequency inverters must not be taken into operation until the associated machine has been confirmed to comply with the safety requirements of Machinery Safety Directive (MSD) 89/392/EEC (meets the requirements of EN 60204). The user of the equipment is responsible for ensuring that the machine use complies with the relevant EU Directives.

The CE markings on the H-Max frequency inverter confirm that, when used in a typical drive configuration, the apparatus complies with the European Low Voltage Directive (LVD) and the EMC Directives (Directive 73/23/EEC, as amended by 93/68/EEC and Directive 89/336/EEC, as amended by 93/68/EEC).

In the described system configurations, H-Max frequency inverters are suitable for use in public and non-public networks.

A connection to IT networks (networks without reference to earth potential) is permissible only to a limited extent, because the device's built-in filter capacitors connect the network with the earth potential (enclosure). On earth free networks, this can lead to dangerous situations or damage to the device (isolation monitoring required).

To the output of the frequency inverter (terminals U, V, W) you must not:

- connect a voltage or capacitive loads (for example, phase compensation capacitors)
- connect multiple frequency inverters in parallel
- make a direct connection to the input (bypass)

Observe the technical data and connection requirements. For additional information, refer to the equipment nameplate or label at the frequency inverter, and the documentation.

Any other usage constitutes improper use.

Maintenance and Inspection

H-Max frequency inverters are maintenance free. However, external influences may affect the function and the lifespan of the H-Max frequency inverter. We therefore recommend that the devices are checked regularly and the following maintenance measures are carried out at the specified intervals.

There are no plans for replacing or repairing individual components of H-Max frequency inverters.

If the H-Max frequency inverter is damaged by external influences, repair is not possible. Dispose of the device in accordance with the respectively applicable environmental laws and provisions for the disposal of electrical or electronic devices.

Maintenance Measures and Intervals

Maintenance Measure	Maintenance Interval
Clean cooling vents (cooling slits)	If required
Check the fan function	6–24 months (depending on the environment)
Filter in the switching cabinet doors (see manufacturer specifications)	6–24 months (depending on the environment)
Check the tightening torques of the terminals (control signal terminals, power terminals)	Regularly
Check connection terminals and all metallic surfaces for corrosion	6–24 months (depending on the environment)

Storage

If the frequency inverter is stored before use, suitable ambient conditions must be ensured at the site of storage:

- Storage temperature: -40° to 158°F (-40° to 70°C)
- Relative average air humidity: $<95\%$, non condensing (EN 50178)
- To prevent damage to the DC link capacitors, storage times longer than 12 months are not recommended

Service and Warranty

In the unlikely event that you have a problem with your H-Max frequency inverter, please contact your local sales office.

When you call, have the following information ready:

- the exact frequency inverter part no. (see nameplate)
- the date of purchase
- a detailed description of the problem that has occurred with the frequency inverter

If some of the information printed on the nameplate is not legible, please state only the information that is clearly legible. This information can also be found on the cover of the control terminals.

Information concerning the guarantee can be found in the Eaton General Terms and Conditions of Sale.

H-Max Series Overview

This chapter describes the purpose and contents of this manual, the receiving inspection recommendations and the H-Max Series Open Drive catalog numbering system.

How to Use this Manual

The purpose of this manual is to provide you with information necessary to install, set and customize parameters, start up, troubleshoot and maintain the Eaton H-Max Series adjustable frequency drive (AFD). To provide for safe installation and operation of the equipment, read the safety guidelines at the beginning of this manual and follow the procedures outlined in the following chapters before connecting power to the H-Max Series AFD. Keep this operating manual handy and distribute to all users, technicians and maintenance personnel for reference.

Receiving and Inspection

The H-Max Series AFD has met a stringent series of factory quality requirements before shipment. It is possible that packaging or equipment damage may have occurred during shipment. After receiving your H-Max Series AFD, please check for the following:

Check to make sure that the package includes the Installation Manual (MN04008005E), Quick Start Guide (MN04008004E) and accessory packet. The accessory packet includes:

- Rubber grommets
- EMC grounding clamps for power cables
- Control cable grounding clamps
- EMC jumper locking clips
- M4 screw for EMC level change (FS7 only)
- Additional grounding screw
- Real time clock battery
- UL conduit plate

Inspect the unit to ensure it was not damaged during shipment.

Make sure that the part number indicated on the nameplate corresponds with the catalog number on your order.

If shipping damage has occurred, please contact and file a claim with the carrier involved immediately.



If the delivery does not correspond to your order, please contact your Eaton Electrical representative.

Note: Do not destroy the packing. The template printed on the protective cardboard can be used for marking the mounting points of the H-Max AFD on the wall or in a cabinet.

Rating Plate

Type:	HMX34AG3D421-B	Made in Finland
Input:	Vin/Uin 3~AC, 380-480, 50/60 Hz, 3.4 A	
Output:	Vout/Uout 3~AC, 0- Vin/Uin, 0-320 Hz, 3.4 A @ 40°C, 2.7A @ 50°C	
Power (IL):	1.5HP: 480V / 1.1kW: 400V	
Chassis:	NEMA Type 1/IP21	
S/N:	123456789012	

Approval Sticker

VAC LISTED 9D42



S/N:123456789012

B.ID: 09391
Code:12345678901234567890123456789012345

Carton Labels (U.S. and Europe)

EATON
Powering Business™
Worldwide

AC DRIVE 0020510471

Type: HMX34AG01221-B

S/N: V12345678901



Code:

INPUT: Uin 3~ AC,380-480V, 50/60 Hz,12A
 OUTPUT: 3~ AC, 0 -Uin, 0-320 Hz, 12A
 Power (IL):5.5kW: 400V/7.5HP: 480V

Firmware:
 Application:

Marks:

POWER CONVERSION EQUIPMENT

Style: H34AG01221EB

EATON CORPORATION

Frequency inverter
 Frequenzumrichter
 Convertisseur des fréquences

07W09

 1 234567 890128

U.S. Carton Label

EATON
Powering Business™
Worldwide

AC DRIVE 0020510471

Type: HMX34AG01221-B

S/N: V12345678901



Code:

INPUT: Uin 3~ AC,380-480V, 50/60 Hz,12A
 OUTPUT: 3~ AC, 0 -Uin, 0-320 Hz, 12A
 Power (IL):1.5HP: 480V/1.1kW: 400V

Firmware:
 Application:

Marks:

POWER CONVERSION EQUIPMENT

Style: H34AG01221MB
 Article: 126943

EATON GmbH

Frequency inverter
 Frequenzumrichter
 Convertisseur des fréquences

07W09



 1 234567 890128

Europe Carton Label

H-Max Series Overview

Catalog Number Selection

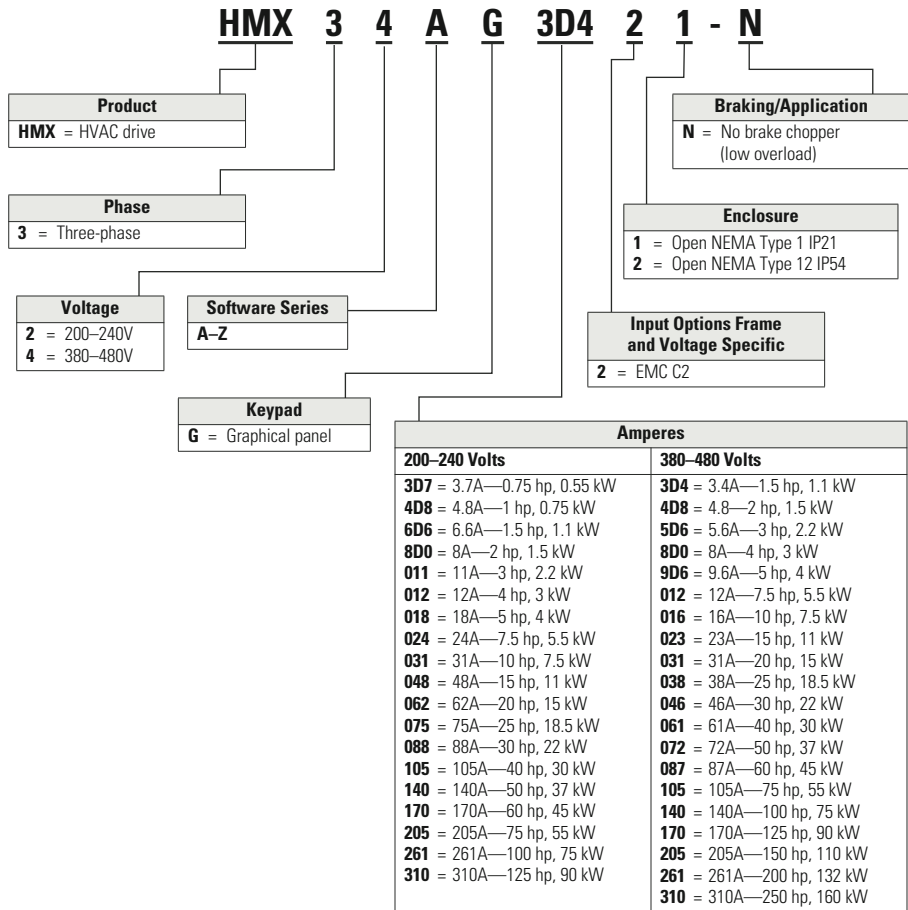
H-Max Series Open Drives



Standard Onboard Communications
RS-485 Communications
BACnet MS/TP = Master slave/token protocol (Universal BACnet) RS-485
Modbus RTU RS-485, ASCII or RTU, remote terminal unit 32 nodes
N2 = Johnson Controls® Metasys® N2 network
Onboard Ethernet-Based Communications (port left side of keypad)
BACnet /IP Ethernet industrial protocol
Modbus /TCP Transmission control protocol (Ethernet-based)

Notes

All boards are varnished (conformed coated). Corrosion resistant.
 Battery included in all drives for real-time clock. Three year lifetime.
 Keypad kit includes HOA bypass.
 Keypad kit includes HOA, back reset for Europe application.
 EMI/RFI filters included.
 DC link choke included.

Power Ratings and Product Selection

H-Max Series Drives—208–230 Volt

NEMA Type 1/IP21 or NEMA Type 12/IP54

FS Frame Size	Drive Rated Current and hp				De-Rated Low Overload Full Load Amps at 50°C	Assigned Motor Ratings Open Drive kW 230V 50 Hz	_ Can Be: 1 = N1 = IP21 2 = N12 = IP54 Catalog Number
	Drive Rating Low Overload Full Load Amps at 40°C	230V 60 Hz Horsepower	Drive Input Amps	NEC Motor 60 Hz 230V Amps ①			
FS4	3.7	0.75	3.2	3.2	2.6	0.55	HMX32AG3D72_-N
	4.8	1	4.3	4.2	3.7	0.75	HMX32AG4D82_-N
	6.6	1.5	6	6	4.6	1.1	HMX32AG6D62_-N
	8	2	7.2	6.8	6.6	1.5	HMX32AG8D02_-N
	11	3	9.7	9.6	8	2.2	HMX32AG0112_-N
	12.5	4	10.9	N/A	9	3	HMX32AG0122_-N
FS5	18	5	16.1	15.2	12.5	4	HMX32AG0182_-N
	24	7.5	21.7	22	18	5.5	HMX32AG0242_-N
	31	10	27.7	28	25	7.5	HMX32AG0312_-N
FS6	48	15	43.8	42	31	11	HMX32AG0482_-N
	62	20	57	54	48	15	HMX32AG0622_-N
FS7	75	25	69	68	62	18.5	HMX32AG0752_-N
	88	30	82.1	80	75	22	HMX32AG0882_-N
	105	40	99	104	88	30	HMX32AG1052_-N
FS8	140	50	133	130	114	37	HMX32AG1402_-N
	170	60	163	154	140	45	HMX32AG1702_-N
	205	75	198	192	170	55	HMX32AG2052_-N
FS9	261	100	256	248	211	75	HMX32AG2612_-N
	310	125	303	N/A	251	90	HMX32AG3102_-N

Note

① For sizing reference, full-load motor running currents—UL508C.

H-Max Series Overview

H-Max Series Drives—380–480 Volt

NEMA Type 1/IP21 or NEMA Type 12/IP54

FS Frame Size	Drive Input Rated Current and hp			NEC Motor 60 Hz 460V Amps ①	De-Rated Low Overload Full Load Amps at 50°C	Assigned Motor Ratings Open Drive kW 400V 50 Hz	_ Can Be: 1 = N1 = IP21 2 = N12 = IP54 Catalog Number
	Low Overload Full Load Amps at 40°C	460V 60 Hz Horsepower	Drive Input Amps				
FS4	3.4	1.5	3.4	3	2.6	1.1	HMX34AG3D42_-N
	4.8	2	4.6	3.4	3.4	1.5	HMX34AG4D82_-N
	5.6	3	5.4	4.8	4.3	2.2	HMX34AG5D62_-N
	8.0	5	8.1	7.6	5.6	3.0	HMX34AG8D02_-N
	9.6	5	9.3	N/A	8	4	HMX34AG9D62_-N
	12	7.5	11.3	11	9.6	5.5	HMX34AG0122_-N
FS5	16	10	15.4	14	12	7.5	HMX34AG0162_-N
	23	15	21.3	21	16	11	HMX34AG0232_-N
	31	20	28.4	27	23	15	HMX34AG0312_-N
FS6	38	25	36.7	34	31	18.5	HMX34AG0382_-N
	46	30	43.6	40	38	22	HMX34AG0462_-N
	61	40	58.2	52	46	30	HMX34AG0612_-N
FS7	72	50	67.5	65	61	37	HMX34AG0722_-N
	87	60	85.3	77	72	45	HMX34AG0872_-N
	105	75	100.6	96	87	55	HMX34AG1052_-N
FS8	140	100	139.4	124	105	75	HMX34AG1402_-N
	170	125	166.5	156	140	90	HMX34AG1702_-N
	205	150	200	180	170	110	HMX34AG2052_-N
FS9	261	200	258	240	205	132	HMX34AG2612_-N
	310	250	303	302	251	160	HMX34AG3102_-N

H-Max Series Adjustable Frequency Drive Option Boards

Option Board Part Number	Assigned to Control Module Slot:	Description
XXM-IO-B1-A	D or E	Expanded 6 digital output—two outputs are programmable as digital inputs or outputs
XXM-IO-B2-A	D or E	Expanded relay outputs—two programmable relays (each with a NO and NC contact) and thermistor input
XXM-IO-B4-A	D or E	Expanded analog inputs and outputs—one analog input and two analog outputs (isolated)
XXM-IO-B5-A	D or E	Expanded relay outputs—contains three programmable relays (one NO contact each)
XXM-IO-B9-A	D or E	Accepts up to five AC inputs (42–240 Vac) and one relay output (NO)
XXM-IO-BF-A	D or E	Expanded analog and digital output—one analog, one digital, and one relay output (NO)
XXM-COM-C4-A	D or E	LonWorks® communication

Note

① For sizing reference, full-load motor running currents—UL508C.

Electrical Installation

WARNING

Carry out wiring work only after the frequency inverter has been correctly mounted and secured.

WARNING

Electric shock hazard—risk of injuries!

Carry out wiring work only if the unit is de-energized.

CAUTION

Debounced inputs may not be used in the safety circuit diagram.

Fire hazard!

Only use cables, protective switches, and contactors that feature the indicated permissible nominal current value.

CAUTION

Debounced inputs may not be used in the safety circuit diagram.

Ground contact currents in frequency inverters are greater than 3.5 mA (AC). According to product standard IEC/EN 61800-5-1, an additional equipment grounding conductor must be connected, or the cross-section of the equipment grounding conductor must be at least 0.39 in² (10 mm²).

WARNING

The components in the frequency inverter's power section remain energized up to five (5) minutes after the supply voltage has been switched off (intermediate circuit capacitor discharging time).

Pay attention to hazard warnings!



DANGER
5 MIN

Note: Complete the following steps with the specified tools and without using force.

Installation Requirements

Installation Requirements

This chapter contains all of the information required to properly install and prepare the H-Max Series AFD for operation. The contents are listed to serve as a list of tasks needed to complete the installation. Included in this section are:

- Line (mains) and motor power wiring
- I/O control wiring

Standard Mounting Instructions

- Select the mounting location based on requirements listed in this chapter
- Mounting surface must be a vertical, flat, non-flammable surface
- H-Max Series open drives may be mounted side-by-side or stacked vertically, as outlined in this chapter
- Surface must be strong enough to support the drive and not subject to excessive motion or vibration
- Mark the location of the mounting holes on the mounting surface, using the template provided on the cover of the cardboard shipping package
- Using fasteners appropriate to your AFD and mounting surface, securely attach the AFD to the mounting surface using all four mounting hole locations

When mounting one unit above the other the lower unit air outlet must be directed away from the inlet air used by the upper one. The clearance between the upper and lower unit should equal C + D.

1. Measure the mounting space to ensure that it allows the minimum space surrounding the VSD Series drive. Drive dimensions are on **Page 21**.
2. Make sure the mounting surface is flat and strong enough to support the drive, is not flammable, and is not subject to excessive motion or vibration.
3. Ensure that the minimum airflow requirements for your drive are met at the mounting location.
4. Mark the location of the mounting holes on the mounting surface, using the template provided on the cover of the cardboard shipping package.
5. Using fasteners appropriate to your drive and mounting surface, securely attached the drive to the mounting surface using all four screws or bolts.

Mounting dimensions:

- Refer to **Page 21** for drive dimensions

Mounting Space

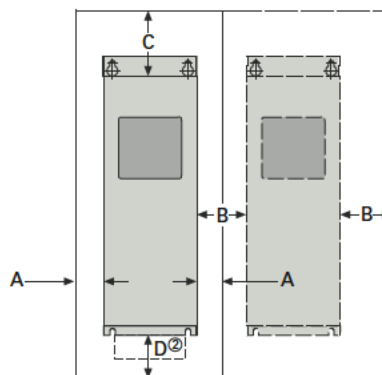

Space Requirements for Mounting the H-Max Series AFD and Airflow

Frame Size	Line Voltage	hp (VT)	kW	Amp	A ^① in (mm)	B ^① in (mm)	C in (mm)	D in (mm)	Cooling Air Required
FS4	230 Vac	0.75–4	0.55–3.0	3.7–12.5	0.8 (20)	0.8 (20)	3.9 (100)	2.0 (50)	27 CFM 45 m ³ /h
	480 Vac	1.5–7.5	1.1–5.5	3.4–12					
FS5	230 Vac	5–10	4–7.5	18–31	0.8 (20)	0.8 (20)	4.7 (120)	2.4 (60)	45 CFM 75 m ³ /h
	480 Vac	10–20	7.5–15	16–31					
FS6	230 Vac	15–20	11–15	48–62	0.8 (20)	0.8 (20)	6.3 (160)	3.1 (80)	112 CFM 190 m ³ /h
	480 Vac	25–40	18.5–30	38–61					
FS7	230 Vac	25–40	18.5–30	75–105	0.8 (20)	0.8 (20)	9.8 (250)	3.9 (100)	109 CFM 185 m ³ /h
	480 Vac	50–75	37–55	72–105					
FS8	230 Vac	50–75	37–55	140–205	0.8 (20)	0.8 (20)	11.9 (300)	6.0 (150)	209 CFM 335 m ³ /h
	480 Vac	100–150	75–110	140–205					
FS9	230 Vac	100–125	75–90	261–310	0.8 (20)	0.8 (20)	13.8 (350)	7.9 (200)	366 CFM 621 m ³ /h
	480 Vac	200–250	132–160	261–310					

Notes

① Minimum clearances A and B for drives with NEMA 12 (IP54) enclosure is 0 mm (in). kW ratings are at 400V/50 Hz.

NEMA Type 1/12 Open Drives (1–250 hp)

Approximate Dimensions in Inches (mm)

Mounting Drive Dimensions

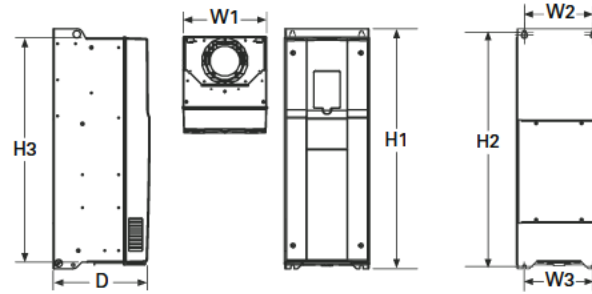

H-Max Series Frames FS4—FS7

Frame Size	Line Voltage	hp (VT)	kW	Amperes	D	H1	Hole Center-to-Center H2	H3	W1	W2	W3	Weight in Lbs (kg)
FS4	230 Vac	0.75–4	0.55–3.0	3.7–12.5	7.77	12.89	12.32	11.22	5.04	3.94	3.94	13.2
	480 Vac	1.5–7.5	1.1–5.5	3.4–12	(197.3)	(327.5)	(313.0)	(285.0)	(128.0)	(100.0)	(100.0)	(6.0)
FS5	230 Vac	5–10	4–7.5	18–31	8.73	16.50	15.98	15.04	5.67	4.53	3.94	22.0
	480 Vac	10–20	7.5–15	16–31	(221.6)	(419.0)	(406.0)	(382.0)	(144.0)	(115.0)	(100.0)	(10.0)
FS6	230 Vac	15–20	11–15	48–62	9.29	21.93	21.28	20.24	7.68	5.83	5.83	44.1
	480 Vac	25–40	18.5–30	38–61	(236.0)	(557.0)	(540.5)	(514.0)	(195.0)	(148.0)	(148.0)	(20.0)
FS7	230 Vac	25–40	18.5–30	75–105	10.49	25.98	25.39	24.29	9.06	7.48	7.48	82.6
	480 Vac	50–75	37–55	72–105	(266.5)	(660.0)	(645.0)	(617.0)	(237.0)	(190.0)	(190.0)	(37.5)

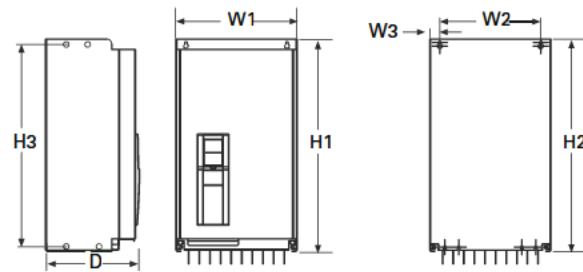

H-Max Series Frames FS7—FS8

Frame Size	Line Voltage	hp (VT)	kW	Amperes	D	H1	Hole Center-to-Center H2	H3	W1	W2	W3	Weight in Lbs (kg)
FS8	230 Vac	50–70	37–55	140–205	13.76	38.02	37.26	37.26	11.42	9.29	1.42	154.3
	480 Vac	100–150	75–110	140–205	(350.0)	(965.7)	(946.0)	(946.0)	(290.0)	(236.0)	(36.0)	(70.0)
FS9	230 Vac	100–125	75–90	261–310	14.63	33.09	31.89	31.89	18.90	15.75	1.57	238.1
	480 Vac	200–250	132–160	261–310	(372.0)	(1150.4)	(810.0)	(810.0)	(480.0)	(400.0)	(40.0)	(108.0)

Installation Requirements

Power Wiring Selection

Line (Mains) and Motor Cable Installation

Motor cable connections are made to terminals U/T₁, V/T₂, and W/T₃.

Cable Selection: Power and Motor Leads

- Use UL approved heat-resistant copper cables only
- 75°C or higher for all units rated <480V
- 90°C or higher for all 480V units
- Line voltage/mains should be Class 1 wire only outside North America
- Refer to the following tables for cable sizing guidelines

North America 208–240V	Page 43
North America 380–480V	Page 44
All other International 380–600V	Page 45

The input line and motor cables must be sized in accordance with the rated H-Max AFD input current.

If motor temperature sensing is used for overload protection, the output cable size may be selected based on the motor specifications.

Maximum symmetrical supply current is 100,000A RMS for all size H-Max AFDs.

Input Fusing

Fuses are rated based on H-Max rated output current.

Use Class T (UL or CSA) or type gG/gL (IEC 60269-1).

Refer to **Pages 43, 44, and 45** for proper fuse size selection.

Fuses with an operating speed of less than 0.4 seconds may be used including the following types:

- High Speed J (UL and CSA)
- aR (UL recognized, IEC 60269-4)
- gS (IEC 60269-4)

Consult with Eaton Electrical for further information on fusing requirements.

Power Connection Tightening Torque

Frame Size	Voltage	hp (VT)	kW	Amperes	Tightening Torque (in-lbs)	Tightening Torque (Nm)
FS4	230 Vac	0.75-4	0.75-3.0	3.7-12.5	5	0.6
	400 Vac	—	1.1-5.5	3.4-12		
	460 Vac	1.5-7.5	—	3.4-12		
FS5	230 Vac	5-10	4-7.5	18-31	13	1.5
	400 Vac	—	7.5-15	16-31		
	460 Vac	10-20	—	16-31		
FS6	230 Vac	15-20	11-15	48-62	35	4
	400 Vac	—	18.5-30	38-61		
	460 Vac	25-40	—	38-61		
FS7	230 Vac	25-40	18.5-30	75-105	88	10
	400 Vac	—	37-55	72-105		
	460 Vac	50-75	—	72-105		
FS8	230 vac	50-75	37-55	140-205	170/8	20/9
	400 Vac	—	75-110	140-205		
	460 Vac	100-150	—	140-205		
FS9	230 Vac	100-125	75-90	261-310	354/195	40/22
	400 Vac	—	132-160	261-310		
	460 Vac	200-250	—	261-310		

Note: Strip the motor and power cables as shown in figure on next page.

Spacing Between Parallel Motor Cables

Cable Length	Distance Between Cables
Less than 164 ft (50 m)	1 ft (0.3m)
Less than 657 ft (200 m)	3 ft (3.3m)

Maximum Cable Length by Frame Size without DV/DT Protected C2 Ratings

Frame Size	Maximum Cable Length
FS4	328 ft (100m)
FS5	493 ft (150m)
FS6	
FS7	657 ft (200m)
FS8	657 ft (200m)
FS9	657 ft (200m)

Installation Requirements

Input Power and Motor Cable Stripping Lengths

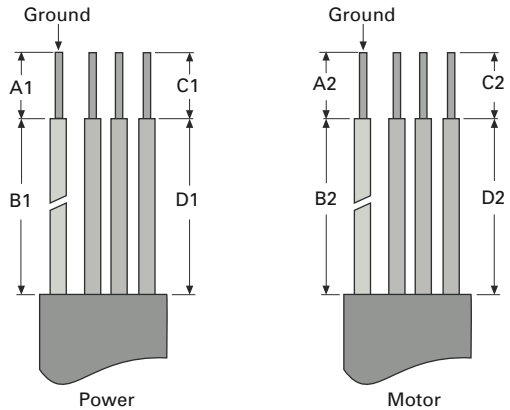

Input Power and Motor Cable Stripping and Wire Lengths

Frame Size	Voltage	hp (VT)	kW	Amperes	Power Wiring in Inches (mm)				Motor Wiring in Inches (mm)			
					A1	B1	C1	D1	A2	B2	C2	C4
FS4	230 Vac	0.75–4	0.55–3.0	3.7–12.5	0.59	1.38	0.39	0.79	0.28	1.97	0.28	1.38
	400 Vac		1.1–5.5	3.4–12	(15)	(35)	(10)	(20)	(7)	(50)	(7)	(35)
	460 Vac	1.5–7.5	—	3.4–12								
FS5	230 Vac	5–10	4–7.5	18–31	0.79	1.57	0.39	1.18	0.79	2.36	0.39	1.57
	400 Vac	—	7.5–15	16–31	(20)	(40)	(10)	(30)	(20)	(60)	(10)	(40)
	460 Vac	10–20	—	16–31								
FS6	230 Vac	15–20	11–15	48–62	0.79	3.54	0.59	2.36	0.79	3.54	0.59	2.36
	400 Vac	—	18.5–30	38–61	(20)	(90)	(15)	(60)	(20)	(90)	(15)	(60)
	460 Vac	25–40	—	38–61								
FS7	230 Vac	25–40	18.5–30	75–105	0.98	4.72	0.98	4.72	0.98	4.72	0.98	4.72
	400 Vac	—	37–55	72–105	(25)	(120)	(25)	(120)	(25)	(120)	(25)	(120)
	460 Vac	50–75	—	72–105								
FS8	230 Vac	50–75	37–55	140–205	1.1	9.45	1.1	9.45	1.1	9.45	1.1	9.45
	400 Vac	—	75–110	140–205	(28)	(240)	(28)	(240)	(28)	(240)	(28)	(240)
	460 Vac	100–150	—	140–205								
FS9	230 Vac	100–125	75–90	261–310	1.1	11.61	1.1	11.61	1.1	11.61	1.1	11.61
	400 Vac	—	132–160	261–310	(28)	(295)	(28)	(295)	(28)	(295)	(28)	(295)
	460 Vac	200–250	—	261–310								

Cable Routing

If conduit is being used for wiring, use separate conduits for line voltage (mains), motor cables, and all interface/control wiring.

Avoid running motor cables alongside or parallel to any other wiring. If it is necessary to run motor cables with other wiring, then maintain spacing between motor cables and other wiring in accordance with the table on **Page 23**.

Refer to the table on **Page 23** for maximum cable lengths by frame size.

If three or more motor cables are used, each conductor must have its own overcurrent protection.

If three or more motor cables are used, each conductor must have its own overcurrent protection.

Wiring the AFD

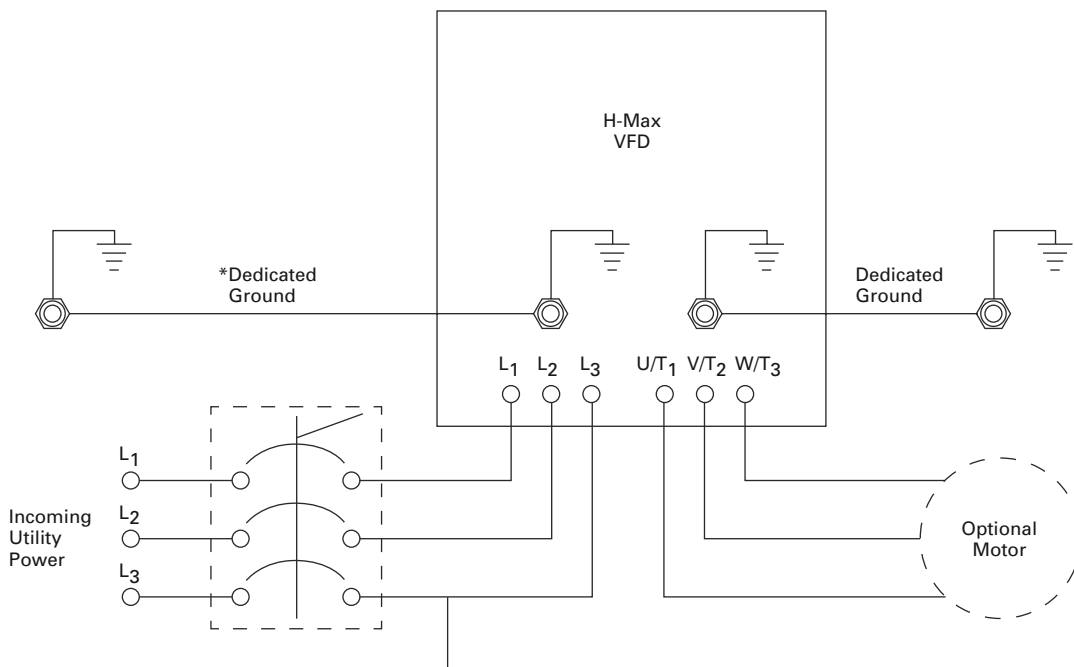

*Conduit Only Does Not Represent Ground.

Installation Requirements

Power Wiring

Notice

Do not discard the plastic bag containing the wiring hardware.

1. Remove the cover by removing (4) screws, then lifting the cover away from the base.

Wiring Hardware Contents

- European rubber grommet and flat rubber grommet (for IP54 integrity).
- Modification label
- Wire (grounding strap)
- Detachable cable clamp
- Attachable grounding clamps
- Ground lug mounting screw size M4



Power Wiring/Grounding

2. Remove power wiring protection plate. Use power/motor cable tables on **Pages 43, 44, and 45**.
3. Add attachable grounding clamps (qty 2), one on each side of drive.
4. Pass motor, input power wires/cables through base wiring plate.
5. If shielded cable is used, connect the shields of input power and motor cables shields to ground.

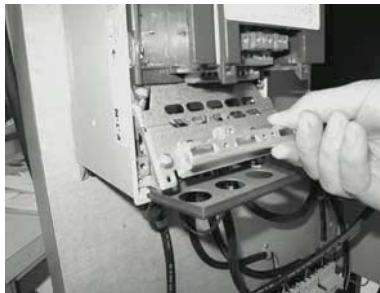

Power Wiring/Grounding, continued

6. Wire power terminals (L1,L2,L3), motor terminal (U/T1, U/T2, U/T3), and grounding terminals per diagram below. Power and motor leads must be in separate conduit.

Note: Do not wire motor leads to R+, R-. This will cause damage to the drive.

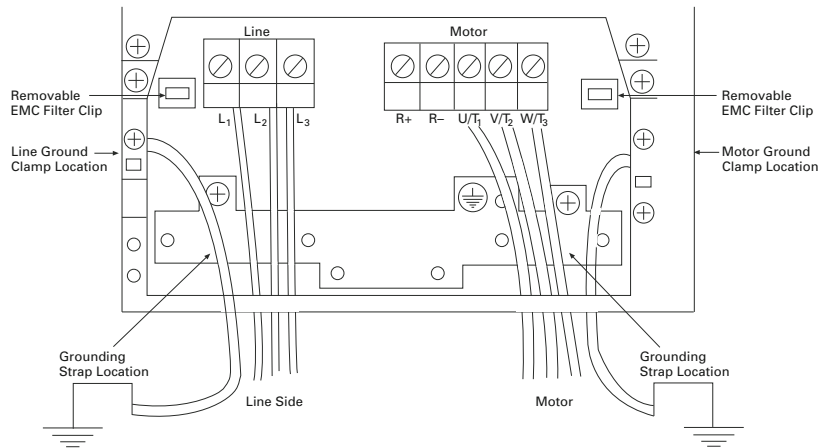

GROUND WIRING

- Run motor cables in separate conduit
- DO NOT RUN CONTROL WIRES in same conduit
- Cables sized per NEC
- Provide **dedicated** wire for low impedance ground between drive and motor. DO NOT USE conduit as ground

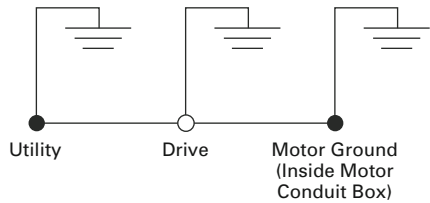

IMPORTANT: Improper grounding could result in damage to the motor and/or drive and could void warranty.

Control Wiring

7. Wire the control terminals following the details for the specific option boards shown on the following pages.

Note: For ease of access, the board terminals blocks can be unplugged for wiring.



Control Board

The main H-Max Series AFD consists of a main control board, control I/O connections block and two slots for extra option boards.

H-Max Series Adjustable Frequency Drive

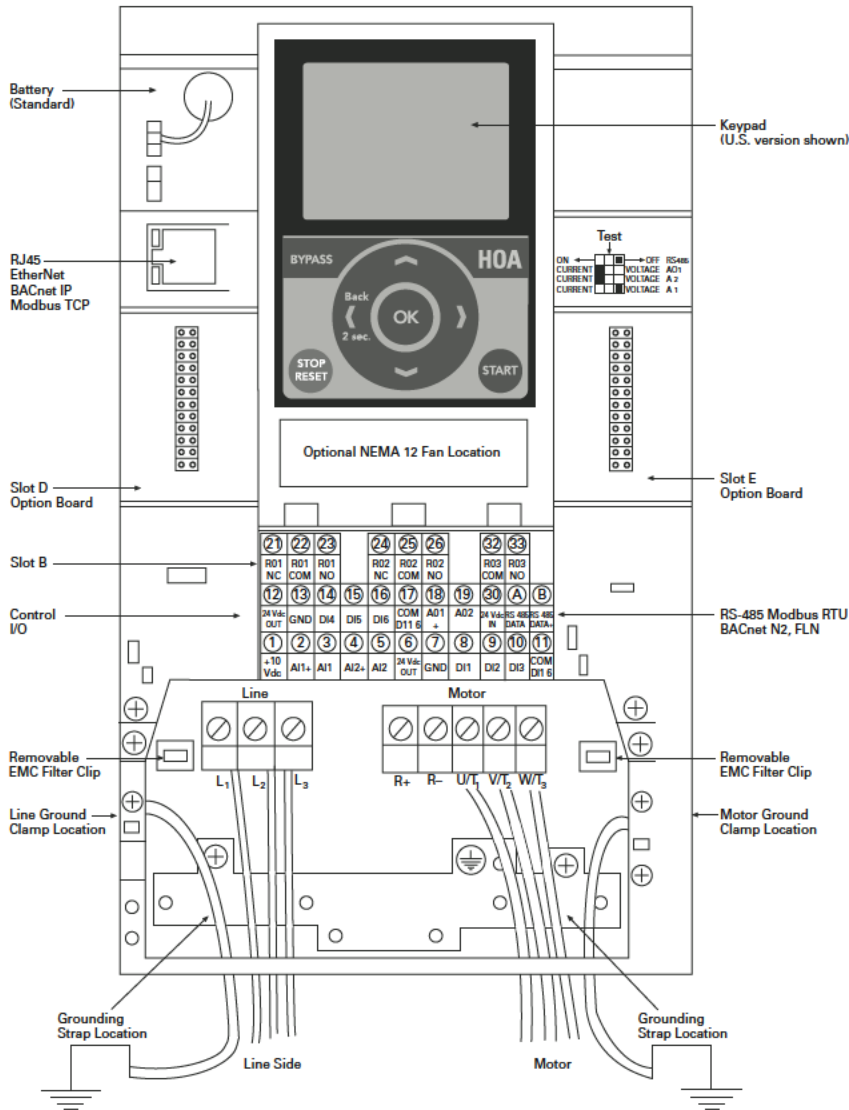

Control Wiring

- All control I/O wiring must be segregated from line (mains) and motor cabling
- Control wiring shall be shielded twisted pairs. To meet EMC levels required by ENG1800-3 (2004). Control wiring must be Type 4 cable
- Run 120 Vac and +24 Vdc control I/O in separate conduit
- Control I/O terminals must be tightened to 4.5 lb (0.5 Nm)

Installation Requirements

EMC Installation

The responsibility to comply with the legally stipulated limit values and thus the provision of electromagnetic compatibility is the responsibility of the end user or system operator. This operator must also take measures to minimize or remove emissions in the environment concerned (see figure on **Page 5**). He must also use means to increase the interference immunity of the system devices.

In a drive system (PDS) with frequency inverters, you should take measures for electromagnetic compatibility (EMC) while doing your planning, because changes or improvements to the installation site, which are required in the installation or while mounting, are normally associated with additional higher costs.

The technology and system of a frequency inverter cause the flow of high frequency leakage current during operation. All grounding measures must therefore be implemented with low impedance connections over a large surface area.

With leakage currents greater than 3.5 mA, in accordance with VDE 0160 or EN 60335, either

- the protective conductor must have a cross-section $\geq 10 \text{ mm}^2$
- the protective conductor must be open-circuit monitored, or
- the second protective conductor must be fitted

For an EMC-compliant installation, we recommend the following measures:

- Installation of the frequency inverter in a metallic, electrically conducting enclosure with a good connection to earth
- Shielded motor cables (short cable lengths)

Ground all conductive components and housings in a drive system using as short a line as possible with the greatest possible cross-section (Cu-braid).

EMC Measures in the Control Panel

For EMC-compatible installation, connect all metallic parts of the device and the switching cabinet together over broad surfaces and so that high-frequencies will be conducted. Mounting plates and cabinet doors should make good contact and be connected with short HF-braided cables. Avoid using painted surfaces (anodized, chromized). An overview of all EMC measures is provided in the figure on **Page 31**.

Install the frequency inverter as directly as possible (without spacers) on a metal plate (mounting plate).

Route input and motor cables in the switch cabinet as close to the ground potential as possible. This is because free moving cables act as antennas.

When laying HF cables (for example, shielded motor cables) or suppressed cables (for example, input supply cables, control circuit and signal cables) in parallel, a minimum clearance of 11.81 in (300 mm) should be ensured in order to prevent the radiation of electromagnetic energy. Separate cable routing should also be ensured when large voltage potential differences are involved. Any necessary crossed cabling between the control signal and power cables should always be implemented at right angles (90 degrees).

Never lay control or signal cables in the same duct as power cables. Analog signal cables (measured, reference and correction values) must be shielded.

Earthing

The ground connection (PE) in the cabinet should be connected from the input supply to a central earth point (mounting plate). All protective conductors should be routed in star formation from this earth point and all conductive components of the PDS (frequency inverter, motor reactor, motor filter, main choke) are to be connected.

Avoid ground loops when installing multiple frequency inverters in one cabinet. Make sure that all metallic devices that are to be grounded have a broad area connection with the mounting plate.

Screen Earth Kit

Cables that are not shielded work like antennas (sending, receiving). Make sure that any cables that may carry disruptive signals (for example, motor cables) and sensitive cables (analog signal and measurement values) are shielded apart from one another with EMC-compatible connections.

The effectiveness of the cable shield depends on a good shield connection and a low shield impedance.

Use only shields with tinned or nickel-plated copper braiding. Braided steel shields are unsuitable.

Control and signal lines (analog, digital) should always be grounded on one end, in the immediate vicinity of the supply voltage source (PES).

Installation Requirements

International EMC Protection Cable Requirements

1st Environment 2nd Environment EMC Levels According to EN61800-3 (2004)

Cable Type	Category C2	Category C3	Level T
Line voltage/mains	1	1	1
Motor cable	3 ①	2	2
Control cable	4	4	4

Cable Categories

Cable Category	Description (All cables are rated for the specific operating voltage)	Recommended Cable Types
1	Intended for fixed installation	MCMK or similar
2	Symmetrical power cable equipped with a concentric protection wire.	MCMK or similar
3	Symmetrical power cable with compact low-impedance shield. Recommended cable transfer impedance of 1–30 Mhz max. See figure below.	MCCMK, EMCCK, or similar
4	Screened cable equipped with compact low-impedance shield	JAMAK, SAB/ ÖCuY-0 or similar

Cable Description

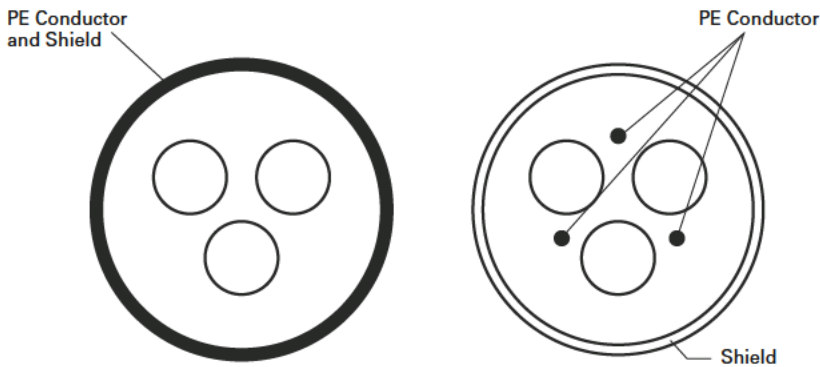

Note

① 360° earthing of the shield with cable glands in motor end needed for EMC Level C2.

Installation in Corner-Grounded Network

Corner grounding is allowed for the drive types rating from 72–310A at 380–480V supply and from 75–310A at 208–240V supply.

In these circumstances the EMC protection class must be changed to level C4 following the instructions below.

Corner grounding is not allowed for the drive types with rating from 3.4–6A at 380–480V supply and 3.7–62A with 208–240V supply.

Installation in IT System

If your supply network is an IT (impedance-grounded) system but your AC drive is EMC-protected according to class C2 you need to modify the EMC protection of the AC drive to EMC level C4. This is done by removing the built-in EMC jumpers with a simple procedure described below:

⚠ WARNING

Do not perform any modifications on the AC drive when it is connected to mains.

Frames FS4 to FS6

Remove the main cover of the AC drive (see figure below) and locate the jumpers connecting the built-in RFI-filters to ground. See figure below.

Locations of the EMC-Jumpers in Frames FS4 to FS6

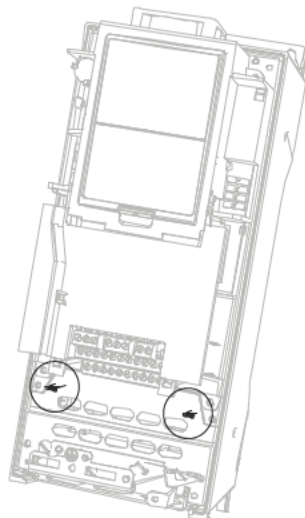

FS4

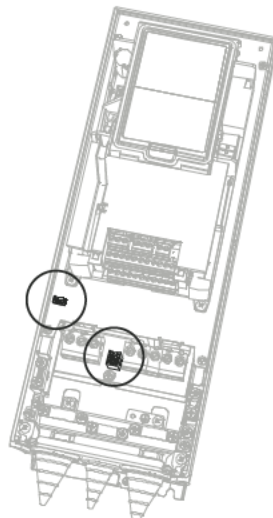

FS5

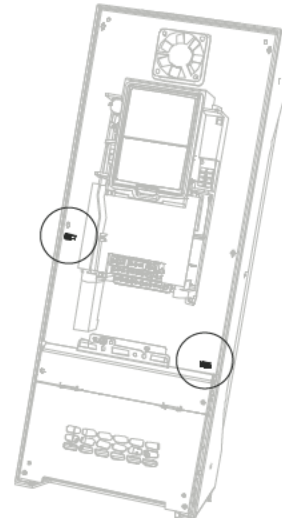

FS6

Installation Requirements

Connection to Power Section

The following figure shows the general connections for the frequency inverter in the power section.

Three-Phase Input Connection

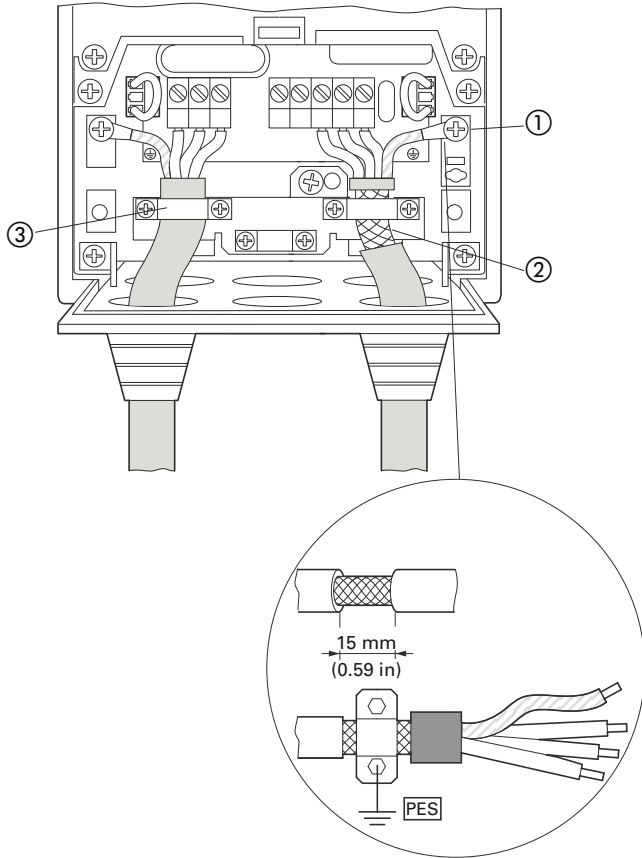

Terminal Designations in the Power Section

- L1, L2, L3: Connection terminals for the supply voltage (input, input voltage):
 - Three-phase AC voltage: Connection to: L1, L2, L3 with HMX32_ and HMX34_.
- U/T1, V/T2, W/T3: Connection terminals for the three-phase line to the AC motor (output, frequency inverter)
- PE: connection for protective ground (reference potential). PES with mounted cable routing plate for shielded cables

Connection to Power Section

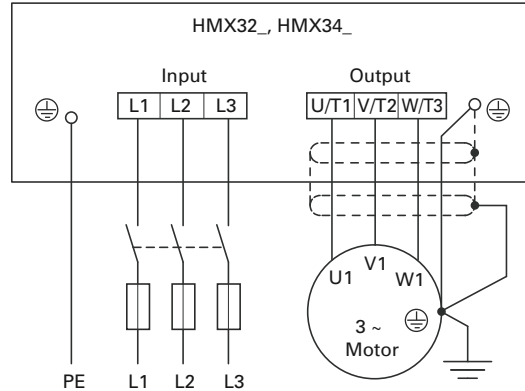

Ground Connection

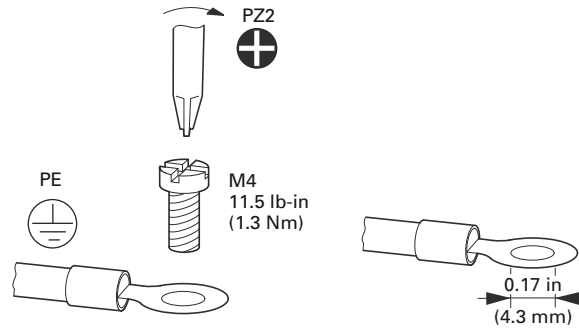

The ground connection is connected directly with the cable clamp plates.

The shielded cables between the frequency inverter and the motor should be as short as possible. Connect the shielding on both ends and over a large surface area with protective ground PES (Protective Earth Shielding). You can connect the shielding of the motor cable directly to the cable clamp plate (360 degrees coverage) with the protective ground.

The frequency inverter must always be connected to the ground potential via a grounding cable (PE).

Disconnect the RFI-filters from ground by removing the EMC-jumpers using long-nose pliers or similar. See figure below.

Removing the Jumper, FS5 as Example

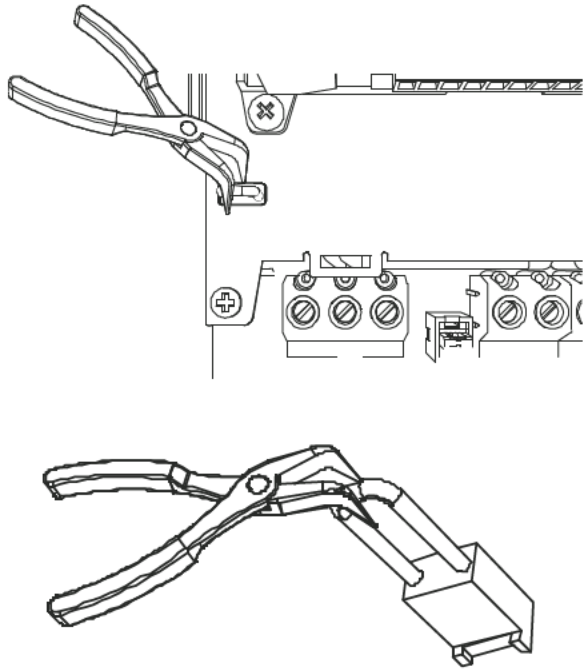

Frames FS7 and FS8

Follow the procedure described below to modify the EMC protection of the AC drive of frames FS7 and FS8 to EMC-level C4.

Remove the main cover of the AC drive and locate the jumper. **FS8 only: Push down** the grounding arm. See figure below.

Grounding Bar Location, FS8

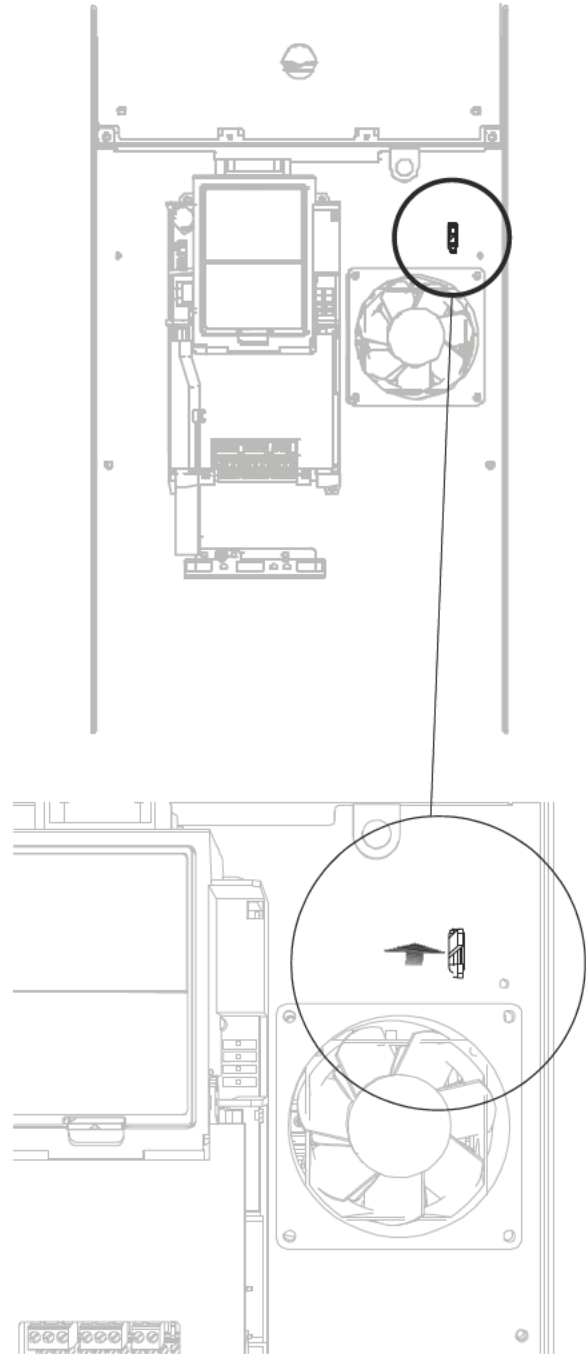

Installation Requirements

FS7 and FS8: Locate the EMC box under the cover. Remove the screws of the box cover to expose the EMC-jumper. Detach the jumper and re-fix the box cover. See figure below.

Removing the EMC Jumper, FS7 and FS8

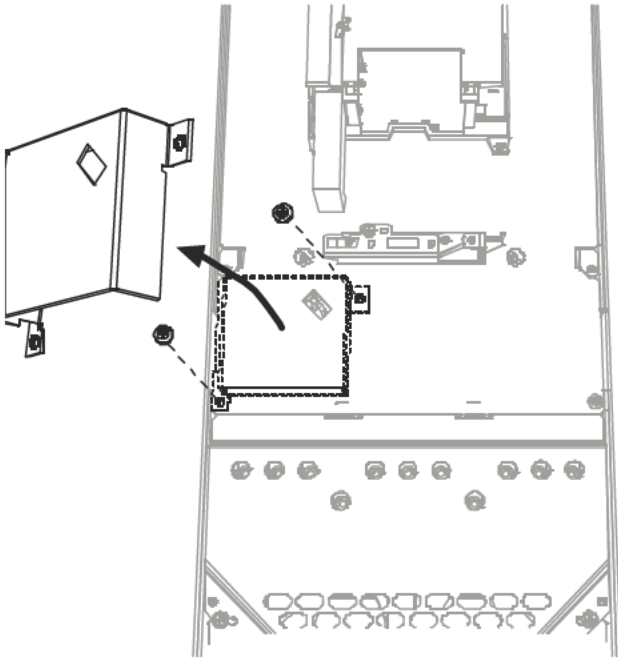

FS7 only: Locate the DC grounding busbar between connectors R- and U and detach the busbar from the frame by undoing the M4 screw. See figure below.

Detaching the DC Grounding Bus Bar from Frame, FS7

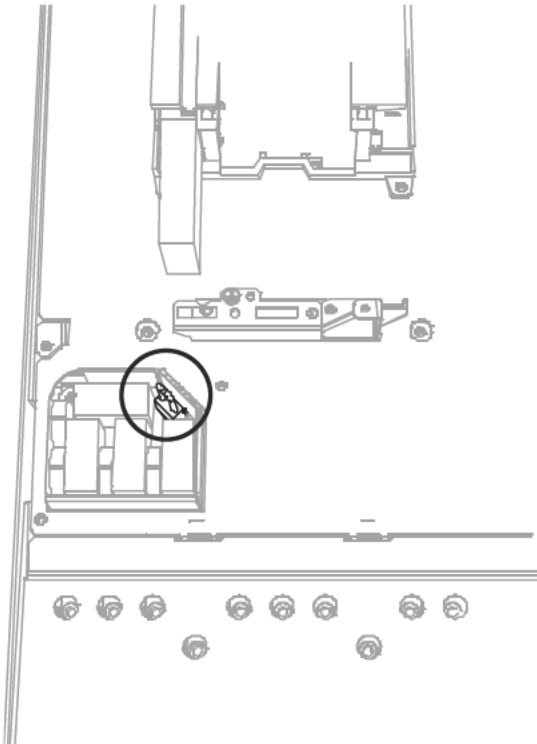
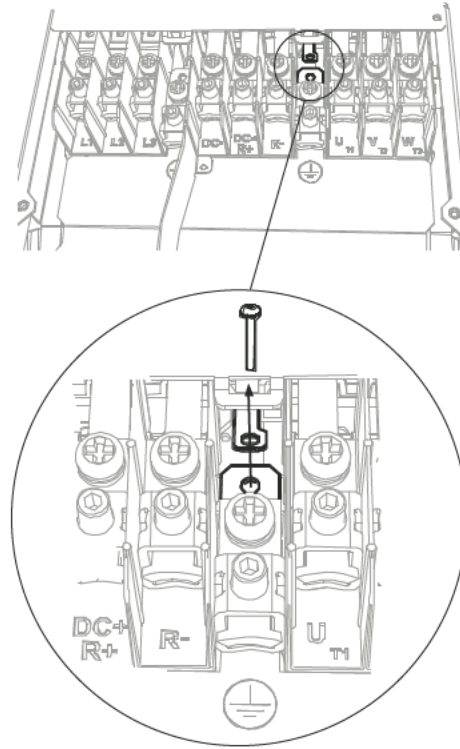

Frame FS9

Follow the procedure described below to modify the EMC protection of the AC drive of frame FS9 to EMC-level C4.

Find the *Molex* connector in the accessories bag. Remove the main cover of the AC drive and locate the place for the connector next to the fan. Push the Molex connector in its place. See figure below.

Molex Connector Placement, FS9

Molex Connector

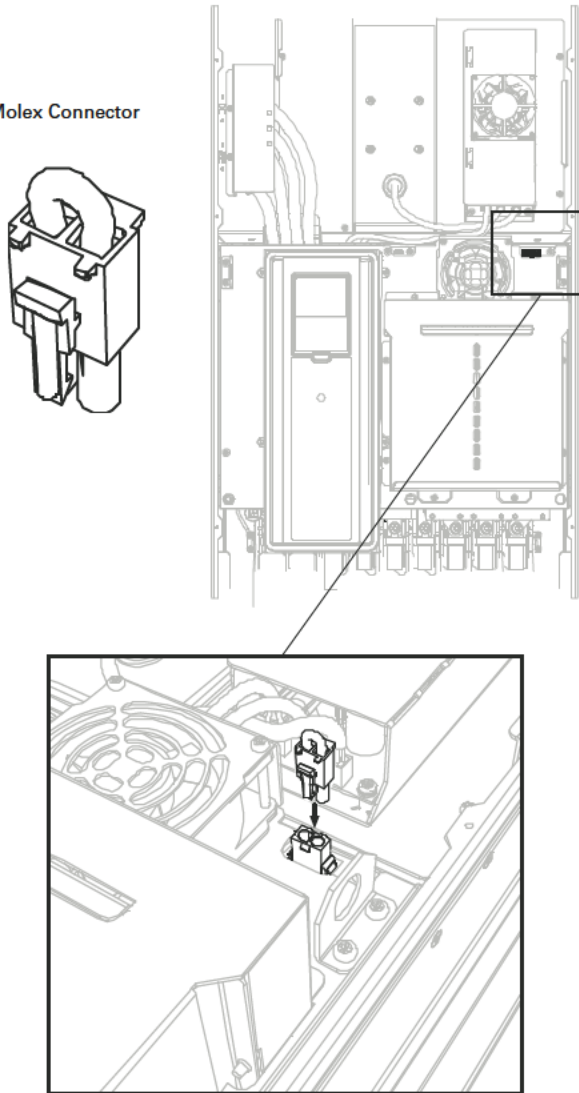

Further remove the extension box cover, the touch shield and the I/O plate with I/O grommet plate. Locate the EMC jumper on the EMC board (see magnification in figure below) and remove it.

Removing the EMC Jumper, FS9

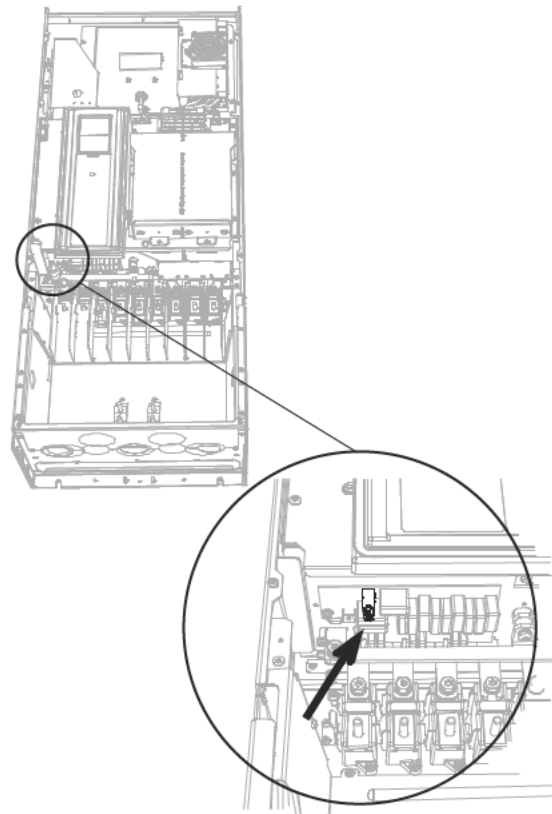

CAUTION

Before connecting the AC drive to mains make sure that the EMC protection class settings of the drive are appropriately made.

Note: After having performed the change write "EMC level modified" on the sticker included in the H-Max delivery (see figure below) and note the date. Unless already done, attach the sticker close to the name plate of the AC drive.

Product Modified Sticker

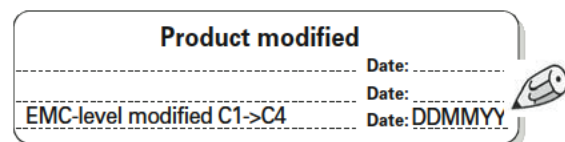

Installation Requirements

Checking the Cable and Motor Insulation

1. Check the motor cable insulation as follows:
 - Disconnect the motor cable from terminals U, V and W of the H-Max Series drive and from the motor
 - Measure the insulation resistance of the motor cable between each phase conductor as well as between each phase conductor and the protective ground conductor
 - The insulation resistance must be >1 mohm
2. Check the input power cable insulation as follows:
 - Disconnect the input power cable from terminals L1, L2 and L3 of the H-Max Series drive and from the utility line feeder
 - Measure the insulation resistance of the input power cable between each phase conductor as well as between each phase conductor and the protective ground conductor
 - The insulation resistance must be >1 mohm
3. Check the motor insulation as follows:
 - Disconnect the motor cable from the motor and open any bridging connections in the motor connection box
 - Measure the insulation resistance of each motor winding. The measurement voltage must equal at least the motor nominal voltage but not exceed 1000V
 - The insulation resistance must be >1 mohm

Appendix A

Technical Data

H-Max Technical Data

Attribute	Description	Specification
Mains connection	Input voltage U_{in}	208–240V, 380–480V, –10 to 10%
	Input frequency	50–60 Hz, –5 to 10%
	Connection to mains	Once per minute or less
	Starting delay	4s (FS4 to FS6), 6s (FS7 to FS9)
Motor connection	Output voltage	0- U_{in}
	Continuous output current	I_L : Ambient temperature maximum 40°C, up to 50°C with derating, overload 1.1 x I_L (1 min./10 min.)
	Output frequency	0–320 Hz (standard)
	Frequency resolution	0.01 Hz
Control characteristics (see parameter P3.1.2.1)	Switching frequency	1.5–10 kHz
	Defaults:	
	FS4–6: 6 kHz (except 0012 2, 0031 2, 0062 2, 0012 4, 0031 4 and 0061 4: 4 kHz)	
	FS7: 4 kHz	
	FS8–9: 3 kHz	
	Automatic switching frequency derating in case of overload.	
	Frequency reference	
	Analog input	Resolution 0.1% (10-bit), accuracy +1%
	Panel reference	Resolution 0.01 Hz
	Field weakening point	8–320 Hz
Acceleration time	0.1–3000 sec.	
Deceleration time	0.1–3000 sec.	
Ambient conditions	Ambient operating temperature	I_L : –10°C (no frost) to 40°C, up to 50°C with derating
	Storage temperature	–40° to 70°C
	Relative humidity	0–95% R_H , non-condensing, non-corrosive
	Air quality:	Tested according to IEC 60068-2-60 Test Ke: Flowing mixed gas corrosion test, Method 1 (H ₂ S [hydrogen sulfide] and SO ₂ [sulfur dioxide])
	• Chemical vapors	Designed according to: IEC 60721-3-3, unit in operation, class 3C2
	• Mechanical particles	IEC 60721-3-3, unit in operation, class 3S2
	Altitude	100% load capacity (no derating) up to 1000m 1% derating for each 100m above 1000m Max. altitudes: 208–240V: 4500m (TN and IT systems) 380–480V: 4500m (TN and IT systems) Voltage for I/O signals: Up to 2000m: Allowed up to 240V 2000–4500m: Allowed up to 120V Corner-grounding: Up to 2000m only

Appendix A

H-Max Technical Data, continued

Attribute	Description	Specification
Ambient conditions, continued	Vibration: <ul style="list-style-type: none"> EN61800-5-1 EN60668-2-6 	5–150 Hz Displacement amplitude: 1 mm (peak) at 5–15.8 Hz (FS4–FS9) Maximum acceleration amplitude: 1g at 15.8–150 Hz (FS4–FS9)
	Shock: <ul style="list-style-type: none"> EN61800-5-1 EN60068-2-27 	UPS drop test (for applicable UPS weights) Storage and shipping: Maximum 15g, 11 ms (in package)
	Enclosure class	IP21/Type 1 standard in entire kW/hp range IP54/Type 12 option Note: Keypad required for IP54/Type12
EMC (at default settings)	Immunity	Fulfills EN61800-3 (2004), first and second environment
	Emissions	+EMC2: EN61800-3 (2004), Category C2 The drive can be modified for IT-networks
Noise level	Average noise level (cooling fan) sound power level in dB(A)	FS4: 65 FS7: 77 FS5: 70 FS8: 86 FS5: 77 FS9: 87
Safety	—	EN61800-5-1 (2007), CE, cUL (see nameplate for more detailed approvals)
Protections	Overvoltage trip limit	240V drives: 456V 480V drives: 911V
	Undervoltage trip limit	Depends on supply voltage (0,8775*supply voltage): Supply voltage 240V: Trip limit 211V Supply voltage 400V: Trip limit 351V Supply voltage 480V: Trip limit 421V
	Earth fault protection	Yes
	Mains supervision	Yes
	Motor phase supervision	Yes
	Overcurrent protection	Yes
	Unit overtemperature protection	Yes
	Motor overload protection	Yes
	Motor stall protection	Yes
	Motor underload protection	Yes
Short-circuit protection of 24V and 10V reference voltages	Yes	

Technical Information on Control Connections

Standard I/O Board

Terminal	Signal	Description
1	Reference output	10V, 3%: Maximum current 10 mA
2	Analog input, voltage or current	Analog input channel 1 0–10V (Ri = 200 kohms) 4–20 mA (Ri = 250 ohms) Resolution 0.1%, accuracy ±1% Selection V/mA with DIP switches Short-circuit protected
3	Analog input common (current)	Differential input if not connected to ground: Allows ±20V differential mode voltage to GND
4	Analog input, voltage or current	Analog input channel 2 Default: 4–20 mA (Ri = 250 ohms) 0–10V (Ri = 200 kohms) Resolution 0.1%, accuracy ±1% Selection V/mA with DIP switches Short-circuit protected
5	Analog input common (current)	Differential input if not connected to ground: Allows 20 differential mode voltage to GND
6	24V auxiliary voltage	24V, ±10%, maximum voltage ripple <100m Vrms, maximum 250 mA Dimensioning: Maximum 1000 mA/control unit Short-circuit protected
7	I/O ground	Ground for reference and controls (connected internally to frame earth through 1 mohms)
8	Digital input 1	Positive or negative logic Ri = minimum 5 kohms
9	Digital input 2	0–5V = "0"
10	Digital input 3	15–30V = "1"
11	Common A for DIN1–DIN6	Digital inputs can be disconnected from ground
12	24V auxiliary voltage	24V, ±10% maximum voltage ripple <100m Vrms, maximum 250 mA Dimensioning: Maximum 1000 mA/control unit Short-circuit protected
13	I/O ground	Ground for reference and controls (connected internally to frame earth through 1 mohms)
14	Digital input 4	Positive or negative logic Ri = minimum 5 kohms
15	Digital input 5	0–5V = "0"
16	Digital input 6	15–30V = "1"
17	Common A for DIN1–DIN6	Digital inputs can be isolated from ground
18	Analog signal (+output)	Analog output channel 1, selection 0–20 mA, load <500 ohms
19	Analog output common	Default: 0–20 mA 0–10V Resolution 0.1%, accuracy ±2% Selection V/mA with DIP switches Short-circuit protected
30	24V auxiliary input voltage	Can be used as external power backup for the control unit
A	RS485	Differential receiver/transmitter
B	RS485	Set bus terminal with DIP switches

Appendix A

Relay Board 1 ^①

Terminal	Signal	Description	
21	Relay output 1 ^②	Switching capacity	24 Vdc/8A
22			250 Vac/8A
23			125 Vdc/0.4A
24	Relay output 2 ^②	Switching capacity	24 Vdc/8A
25			250 Vac/8A
26			125 Vdc/0.4A
32	Relay output 3 ^②	Switching capacity	24 Vdc/8A
33			250 Vac/8A
			125 Vdc/0.4A
		Minimum switching load	5V/10 mA

Relay Board 2 ^③

Terminal	Signal	Description	
21	Relay output 1 ^②	Switching capacity	24 Vdc/8A
22			250 Vac/8A
23			125 Vdc/0.4A
24	Relay output 2 ^②	Switching capacity	24 Vdc/8A
25			250 Vac/8A
26			125 Vdc/0.4A
28	Thermistor input	Rtrip = 4.7 kohms (PTC), measuring voltage 3.5V	
29			

Notes

- ① Relay board with two change-over contact (SPDT) relays and one relay with normally-open (NO or SPST) contact. 5.5 mm isolation between channels.
- ② If 230 Vac is used as control voltage from the output relays, the control circuitry must be powered with a separate isolation transformer to limit short circuit current and overvoltage spikes. This is to prevent welding on the relay contacts. Refer to standard EN60204-1, section 7.2.9.
- ③ Relay board with two change-over contact (SPDT) relays and a PTC thermistor input. 5.5 mm isolation between channels.

Appendix B

Cable Power and Motor Wiring Guidelines

See **Page 24** for cable stripping guidelines.

North America Cable and Fuse Sizes—208–240 Vac Ratings

Frame	Amp Suffix	hp	NEC Motor Amp Rating at 208 Vac	NEC Motor Amp Rating at 230 Vac	AFD I(L) Amps at 40°C	AFD I(L) Amps at 50°C	[kW] 230V at 50 Hz	Fuse Rating (Class T)	NEC Wire Size (AWG)		Terminal Connection Size (AWG)	
									Line and Motor	Ground	Line and Motor	Ground
FS4	3D7	0.75	3.5	2.2	3.7	2.6	0.55	10	14	14	24–10	18–10
	4D8	1.0	4.6	4.2	4.8	3.7	0.75	10	14	14	24–10	18–10
	6D6	1.5	6.6	6.0	6.6	4.6	1.1	10	14	14	24–10	18–10
	8D0	2	7.5	6.8	8.0	6.6	1.5	10	14	14	24–10	18–10
	011	3	10.6	9.6	11	8.0	2.2	15	14	14	24–10	18–10
	012	4	N/A	N/A	12	9.0	3	15	14	14	24–10	18–10
FS5	018	5	16.7	15.2	18	12.5	4	20	12	12	20–6	18–8
	024	7.5	24.2	22	24	18.0	5.5	30	10	10	20–6	18–8
	031	10	30.8	28	31	25.0	7.5	40	8	10	20–6	18–8
FS6	048	15	46.2	42	48	31.0	11	60	4	8	14–0	14–2
	062	20	59.4	54	62	48	15	80	3	8	14–0	14–2
FS7	075	25	74.9	68	75	62	18.5	100	2	8	10–2/0	10–2/0
	088	30	88	80	88	75	22	110	1	6	10–2/0	10–2/0
	105	40	114	104	105	88	30	125	2/0	6	10–2/0	10–2/0
FS8	140	50	143	130	140	114	37	175	2/0	6	1–350 kcmil	1–350 kcmil
	170	60	169	154	170	140	45	200	250 kcmil	6	1–350 kcmil	1–350 kcmil
	205	75	211	192	205	170	55	250	350 kcmil	4	1–350 kcmil	1–350 kcmil
FS9	261	100	273	248	261	211	75	350	500 kcmil	4	1–350 kcmil	1–350 kcmil
	310	125	343	312	310	251	90	400	2X 250 kcmil	3	1–350 kcmil	1–350 kcmil

Note:

1. If power cubes are used, a UL recognized Type T fuse is recommended.
2. Based on maximum environment of 104°F (40°C).
3. If bypass is used, a UL recognized Type T fuse is recommended.

Appendix B

North America Cable and Fuse Sizes—380–480 Vac Ratings

Frame	Amp Suffix	hp	NEC Motor Amp Rating at 480 Vac	AFD I(L) Amps at 40°C	AFD I(L) Amps at 50°C	[kW] 230V at 50 Hz	Fuse Rating (Class T)	NEC Wire Size (AWG)		Terminal Connection Size (AWG)	
								Line and Motor	Ground	Line and Motor	Ground
FS4	3D4	1.5	3	3.4	2.6	1.1	10	14	14	24–10	18–10
	4D8	2	3.4	4.8	3.4	1.5	10	14	14	24–10	18–10
	5D6	3	4.8	5.6	4.3	2.2	10	14	14	24–10	18–10
	8D0	4	N/A	8.0	5.6	3.0	10	14	14	24–10	18–10
	9D6	5	7.6	9.6	8	4	15	14	14	24–10	18–10
	012	7.5	11	12	9.6	5.5	15	12	14	24–10	18–10
FS5	016	10	14	16	12	7.5	20	10	12	20–6	18–8
	023	15	21	23	16	11	30	10	10	20–6	18–8
	031	20	27	31	23	15	35	8	8	20–6	18–8
FS6	038	25	34	38	31	18.5	50	6	8	14–0	14–2
	046	30	40	46	38	22	60	4	8	14–0	14–2
	061	40	52	61	46	30	80	2	6	14–0	14–2
FS7	072	50	65	72	61	37	100	2	6	10–2/0	10–2/0
	087	60	77	87	72	45	110	1	6	10–2/0	10–2/0
	105	75	96	105	87	55	125	1/0	4	10–2/0	10–2/0
FS8	140	100	124	140	105	75	175	3/0	2	1–350 kcmil	1–350 kcmil
	170	125	156	170	140	90	200	4/0	0	1–350 kcmil	1–350 kcmil
	205	150	180	205	170	110	250	300	2/0	1–350 kcmil	1–350 kcmil
FS9	261	200	240	261	205	132	350	350	3/0	1–350 kcmil	1–350 kcmil
	310	250	302	310	251	160	400	2 x 250	300	1–350 kcmil	1–350 kcmil

Note:

1. If power cubes are used, a UL recognized Type T fuse is recommended.
2. Based on maximum environment of 104°F (40°C).
3. If bypass is used, a UL recognized Type T fuse is recommended.

International Cable and Fuse Sizes 380–480 Vac Ratings

Frame	Amp Suffix	AFD I(L) Amps at 40° C	AFD I(L) Amps at 50° C	[kW] 400V at 50 Hz	Fuse Rating (gG/gL)	Mains and Motor Cable Cu (mm ²)	Terminal Cable Size Main Terminal Cu (mm ²)	Earth Terminal Cu (mm ²)
FS4	3D4	3.4	2.6	1.1	6	3*1.5+1.5	1–6 solid or 1–4 stranded	1–6
	4D8	4.8	3.4	1.5	6	3*1.5+1.5	1–6 solid or 1–4 stranded	1–6
	5D6	5.6	4.3	2.2	10	3*1.5+1.53	1–6 solid or 1–4 stranded	1–6
	8D0	8.0	5.6	3.0	16	3*2.5+2.5	1–6 solid or 1–4 stranded	1–6
	9D6	9.6	8	4	16	3*2.5+2.5	1–6 solid or 1–4 stranded	1–6
	012	16	12	7.5	16	3*2.5+2.5	1–6 solid or 1–4 stranded	1–6
FS5	016	23	16	11	20	3*6+6	1–10	1–10
	023	31	23	15	25	3*6+6	1–10	1–10
	031	38	31	18.5	32	3*10+10	1–10	1–10
FS6	038	46	38	22	40	3*10+10	2.5–50	2.5–35
	046	61	46	30	50	3*16+16	2.5–50	2.5–35
	061	72	61	37	63	3*25+16	2.5–50	2.5–35
FS7	072	87	72	45	80	3*35+16	6–70	6–70
	087	105	87	55	100	3*35+16	6–70	6–70
	105	140	105	75	125	3*50+25	6–70	6–70
FS8	140	170	140	90	160	3*70+35	35–185	6–70
	170	205	170	110	200	3*95+50	35–185	6–70
	205	261	205	132	250	3*120+70	35–185	6–70
FS9	261	310	251	160	315	3*185+95	35–185	6–95
	310	3.4	2.6	1.1	350	2*3*95+50	35–185	6–95

Note:

1. If power cubes are used, a UL recognized Type T fuse is recommended.
2. Based on maximum environment of 104°F (40°C).
3. If bypass is used, a UL recognized Type T fuse is recommended.

Appendix C

Dimension Drawings

FS4 Dimension Drawing

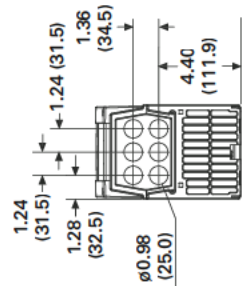
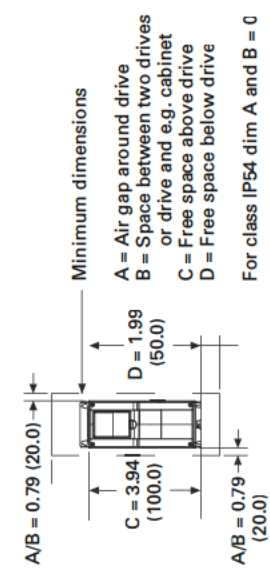
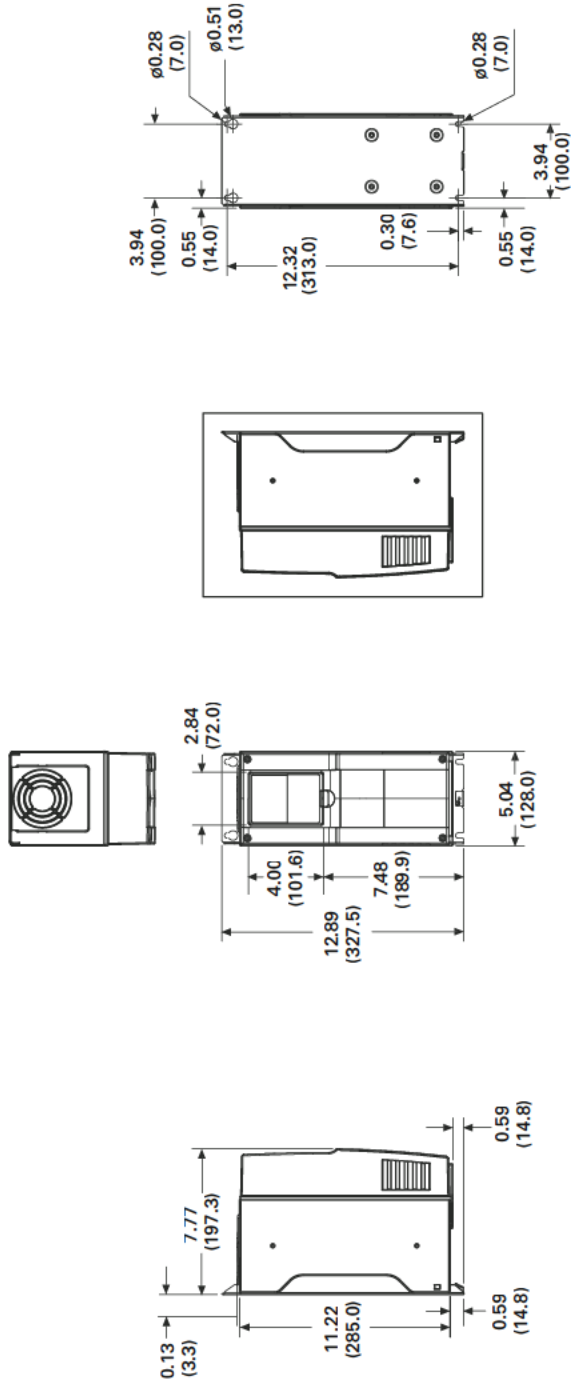

Dimensions = Inches (mm)
 2 FS4 NEMA Type 1/IP24
 NEMA Type 12/IP54

Frame size	Voltage	HP (VT)	kW	Amps	Weight Lbs (kg)
4	230 Vac	0.74-4 HP	55-3.0	3.7-12.5	13.2 (6.0)
	460 Vac	1.5-7.5 HP	1.1-5.5	3.4-12.0	13.2 (6.0)

FS4 Dimension Drawing Flange Mount

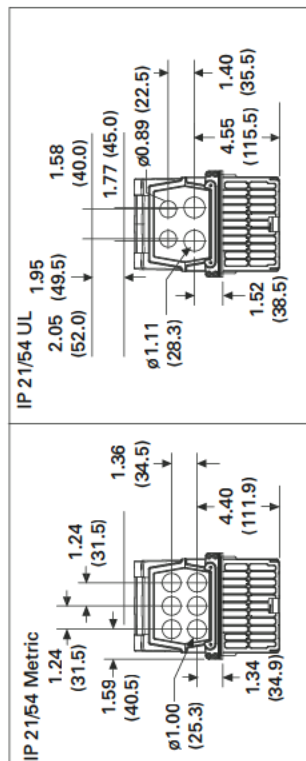
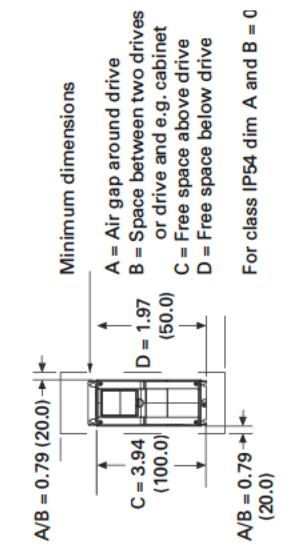
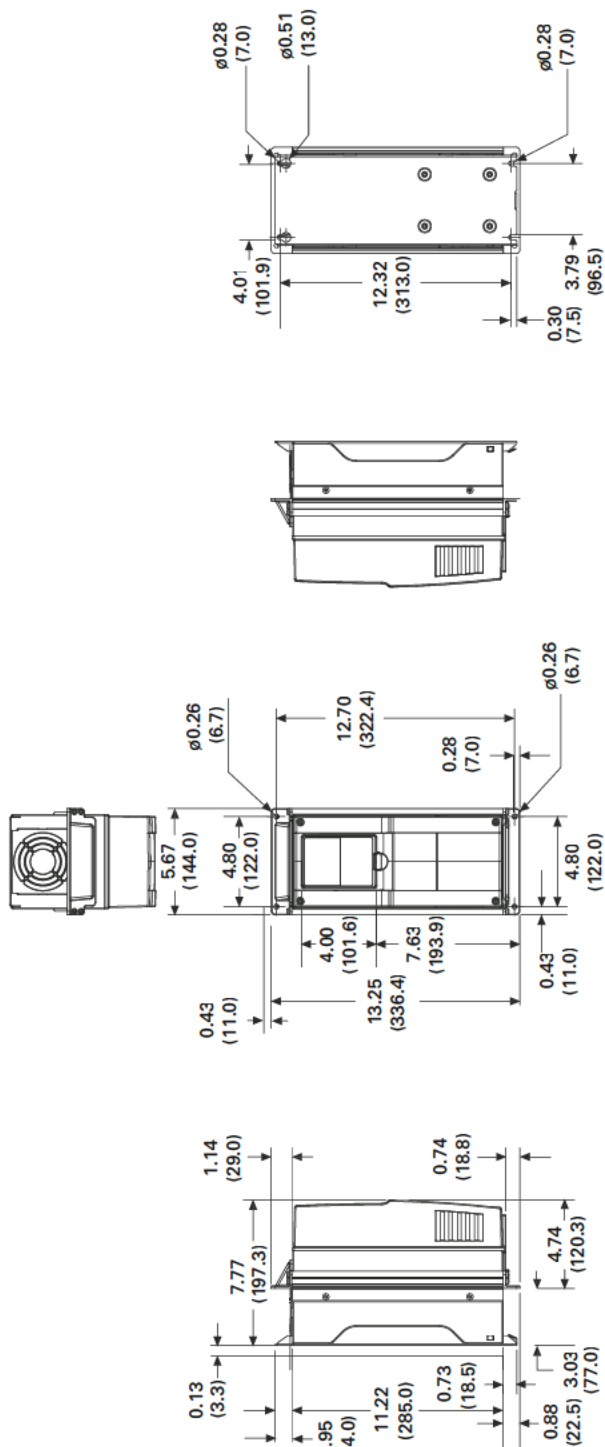

Dimensions = Inches (mm)
 2 FS4 NEMA Type 11/IP21
 NEMA Type 12/IP54

Frame size	Voltage	HP (VT)	kW	Amps	Weight Lbs (kg)
4	230 Vac	0.74-4 HP	55-3.0	3.7-12.5	13.2 (6.0)
4	460 Vac	1.5-7.5 HP	1.1-5.5	3.4-12.0	13.2 (6.0)

FS5 Dimension Drawing

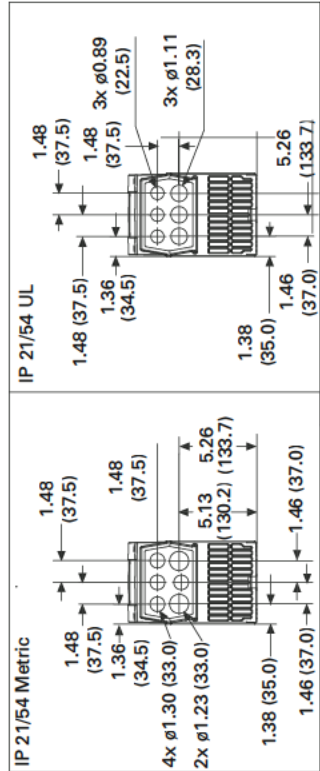
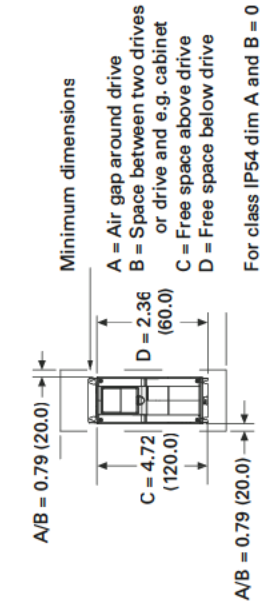
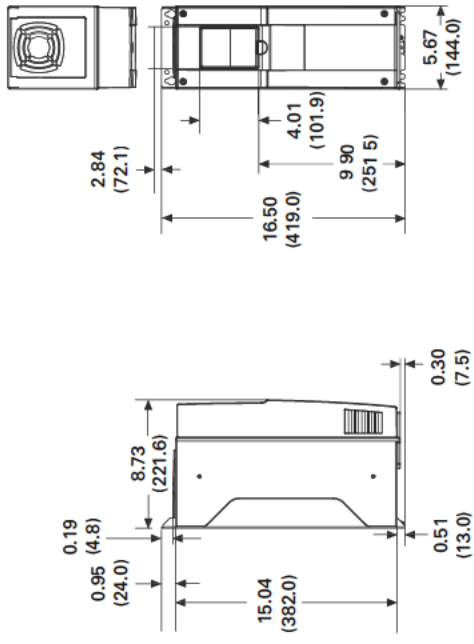
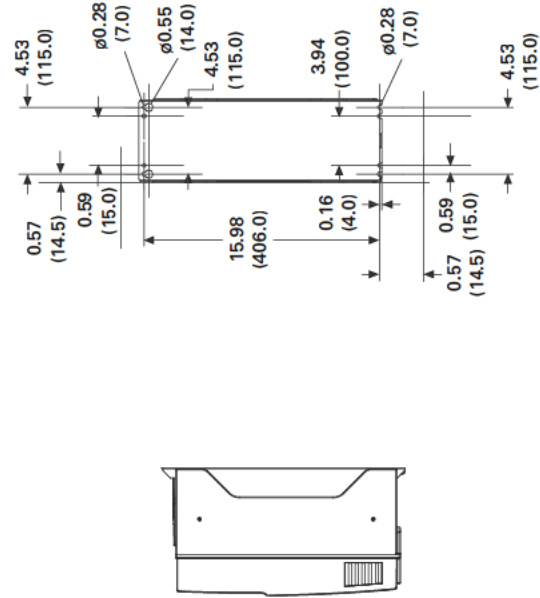

Dimensions = Inches (mm)
 2 FS4 NEMA Type 1/IP24
 NEMA Type 12/IP54

Frame size	Voltage	HP (VT)	kW	Amps	Weight	
					Lbs (kg)	
5	230 Vac	5-10 HP	4-7.5	18-31	22 (10)	
	460 Vac	10-20 HP	7.5-15	16-31	22 (10)	

FS5 Dimension Drawing Flange Mount

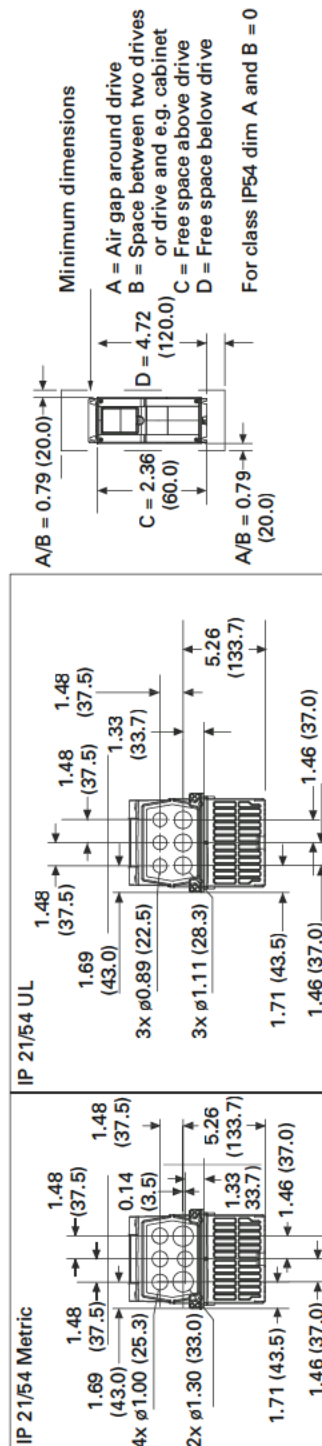
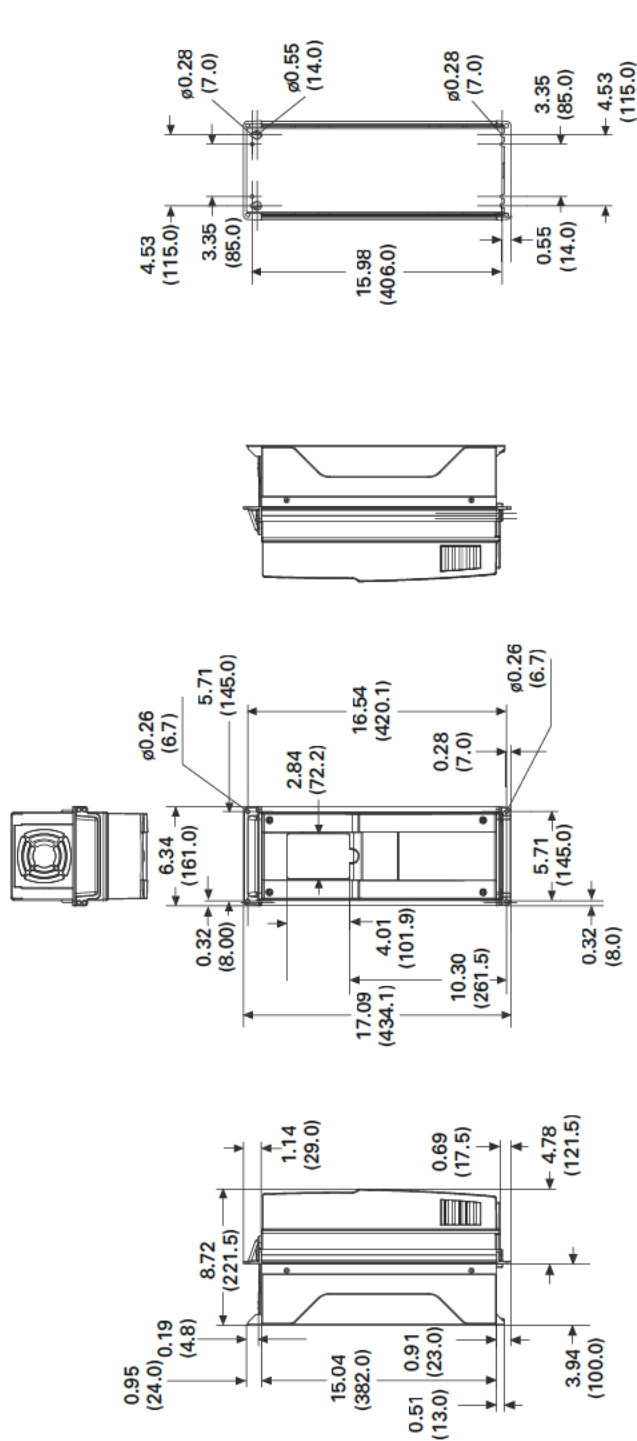

Dimensions = Inches (mm)
 2 FS4 NEMA Type 1/IP24
 NEMA Type 12/IP54

Frame size	Voltage	HP (VT)	kW	Amps	Weight	
					Lbs (kg)	
5	230 Vac	5-10 HP	4-7.5	18-31	22 (10)	
	460 Vac	10-20 HP	7.5-15	16-31	22 (10)	

FS6 Dimension Drawing

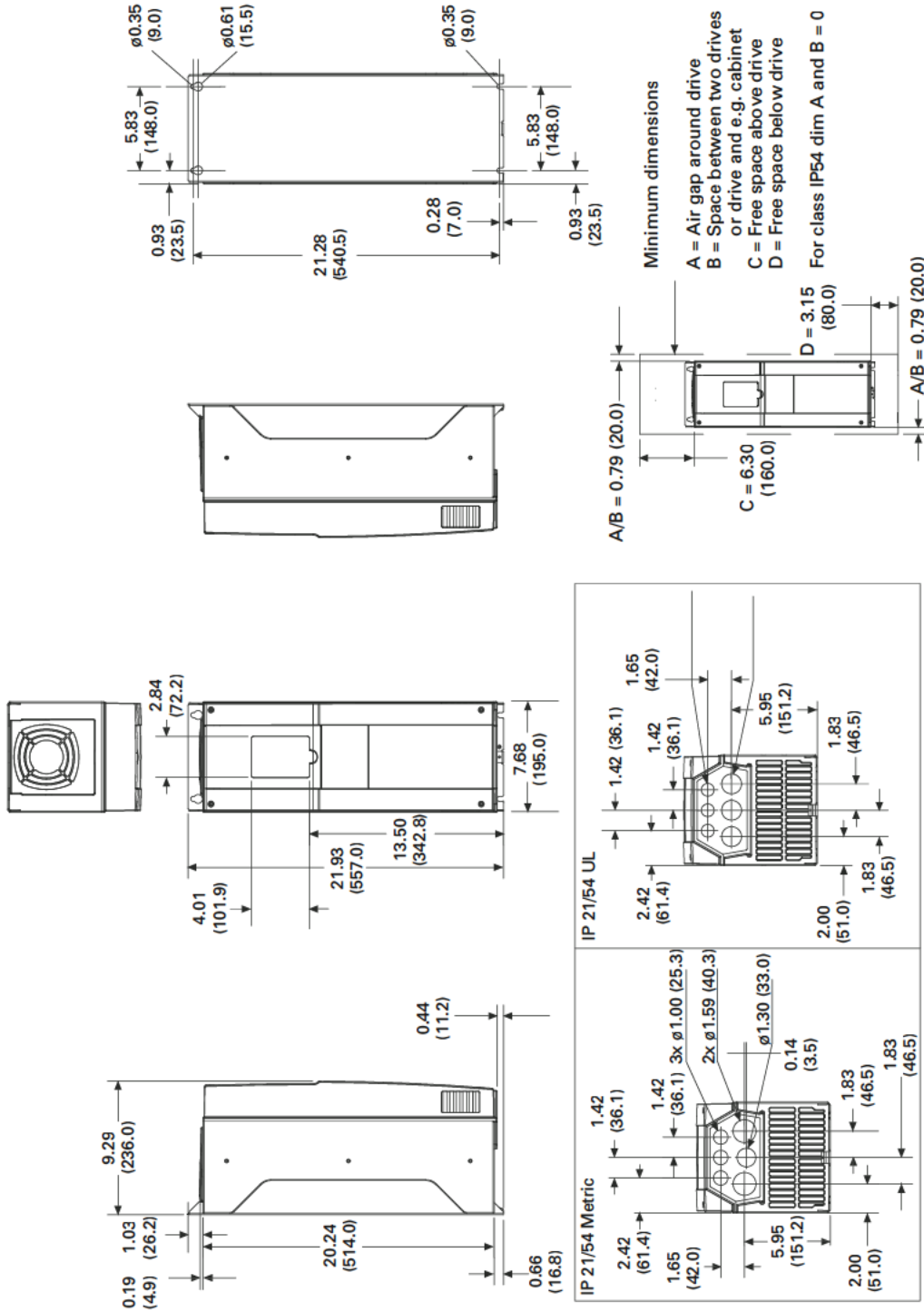

FS6 Dimension Drawing Flange Mount

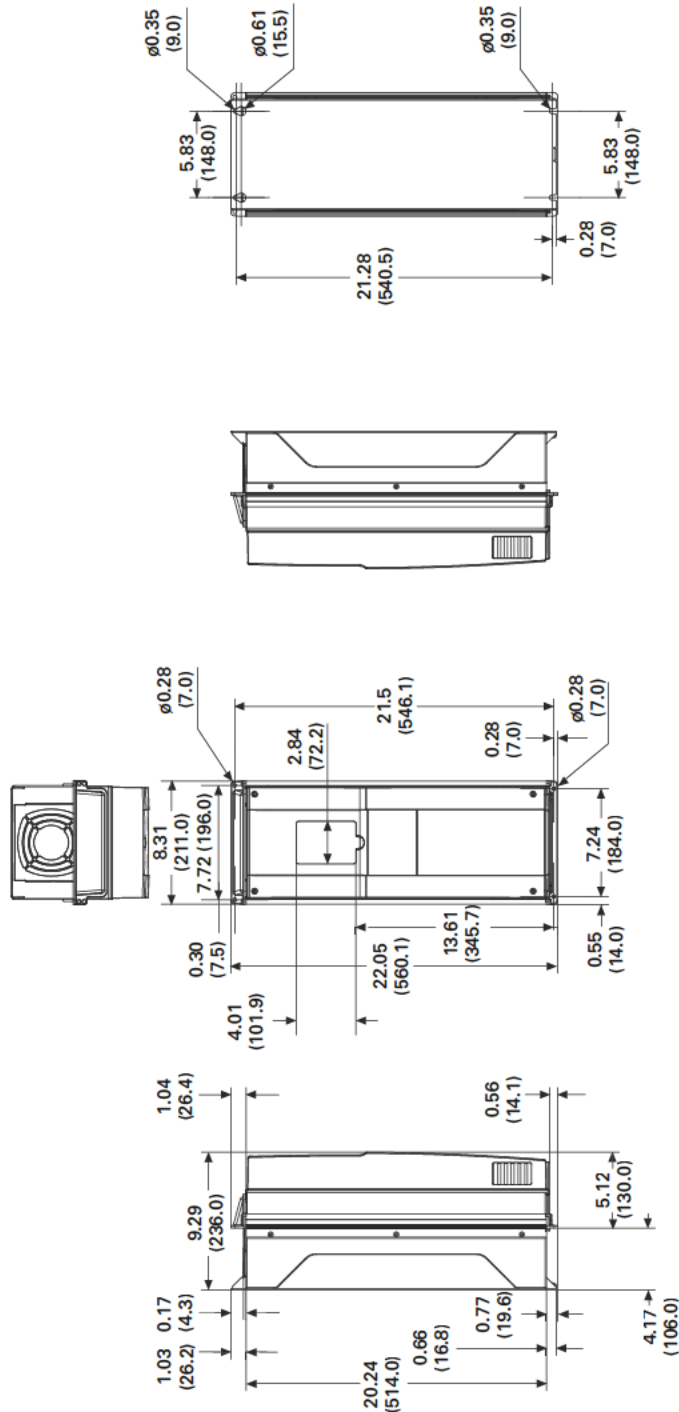

Minimum dimensions
 A = Air gap around drive
 B = Space between two drives or drive and e.g. cabinet
 C = Free space above drive
 D = Free space below drive
 For class IP54 dim A and B = 0

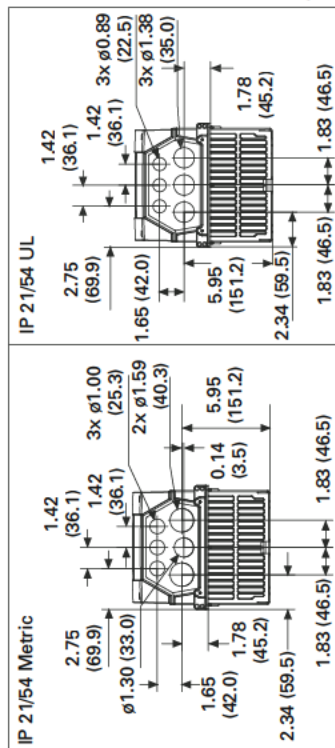
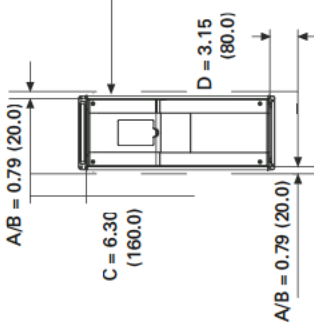

Dimensions = Inches (mm)
 2 FS4 NEMA Type 1/IP24
 NEMA Type 12/IP54

Frame size	Voltage	HP (VT)	kW	Amps	Weight
	230 Vac	5-10 HP	11-15	48-62	Lbs (kg)
6	460 Vac	10-20 HP	18.5-30	36-61	44.1 (20) 44.1 (20)

FS7 Dimension Drawing Flange Mount

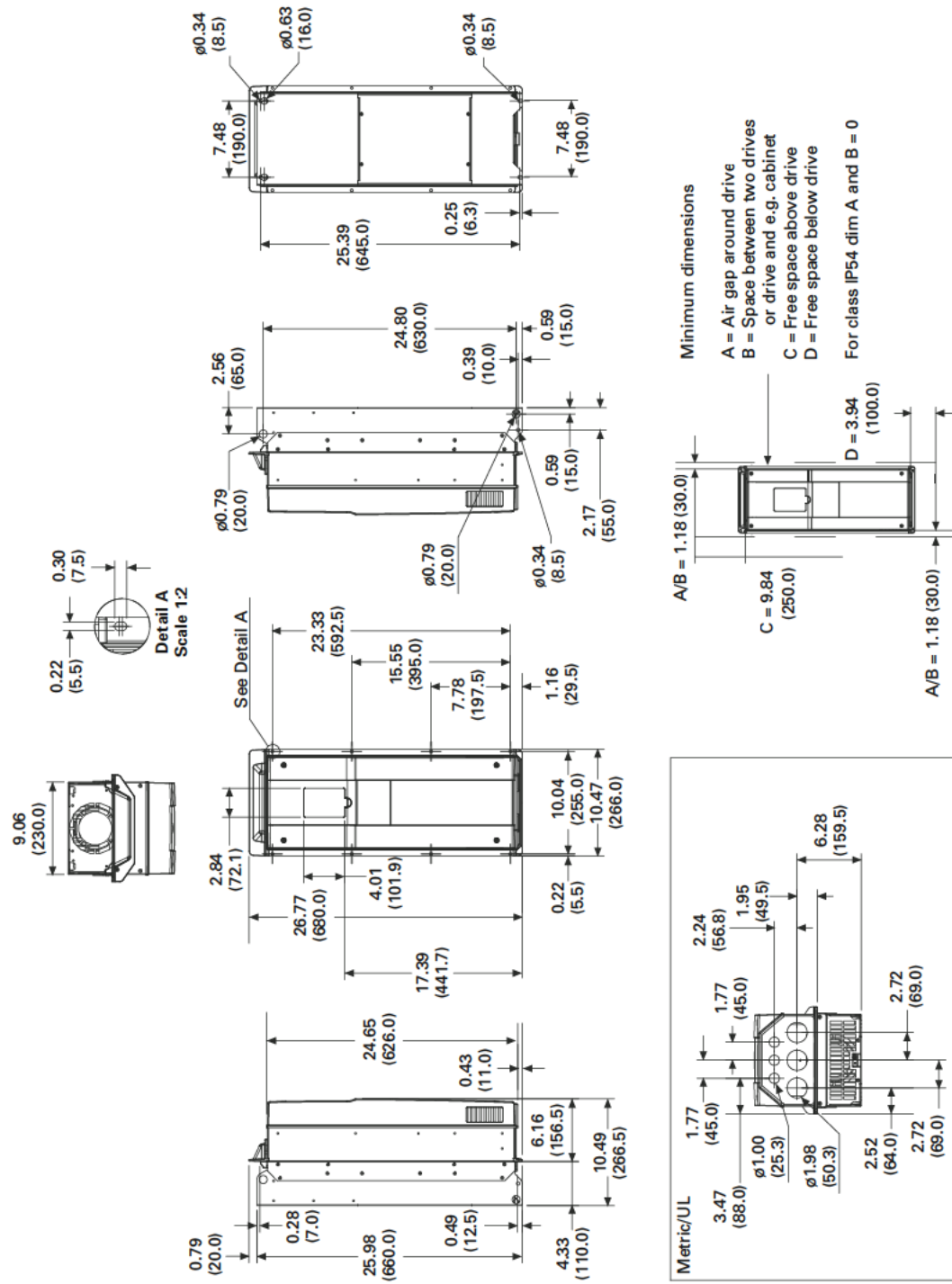

Dimensions = Inches (mm)

Frame size	Voltage	HP (VT)	kW	Amps	Weight Lbs (kg)
7	230 Vac	25-40 HP	18.5-30	75-105	82.6 (37.5)
	460 Vac	50-75 HP	37-55	72-105	82.6 (37.5)

FS8 Dimension Drawing IP00

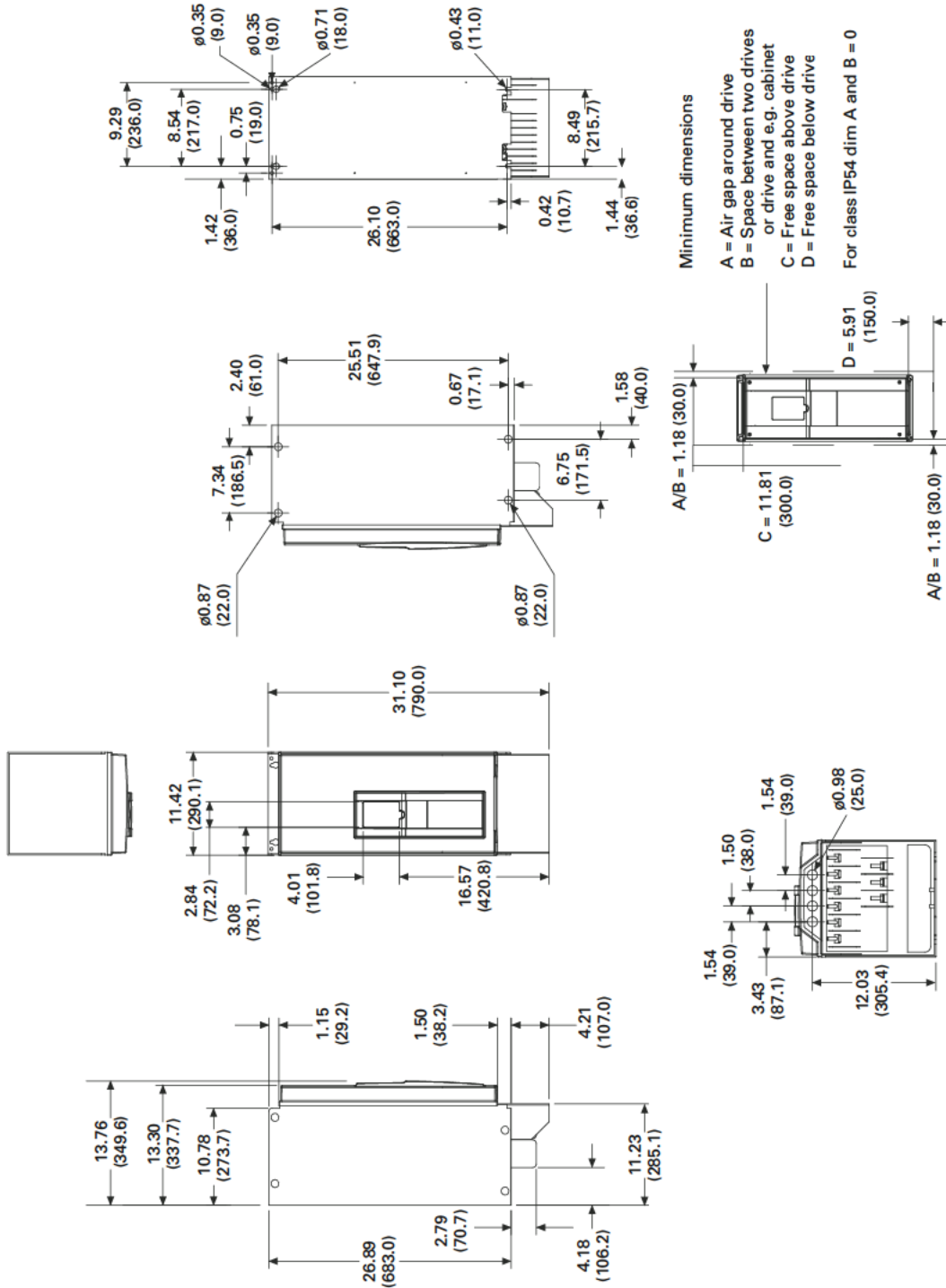

Minimum dimensions

- A = Air gap around drive
 - B = Space between two drives or drive and e.g. cabinet
 - C = Free space above drive
 - D = Free space below drive
- For class IP54 dim A and B = 0

Dimensions= Inches (mm)
FR8 OPEN Chassis/IP00
To be mounted in enclosure

Frame size	Voltage	HP (VT)	kW	Amps	Weight Lbs (kg)
8	230 Vac	50-75 HP	37-55	104-205	154 (70)
	460 Vac	100-150 HP	75-110	140-205	154 (70)

FS8 Dimension Drawing Flange Mount

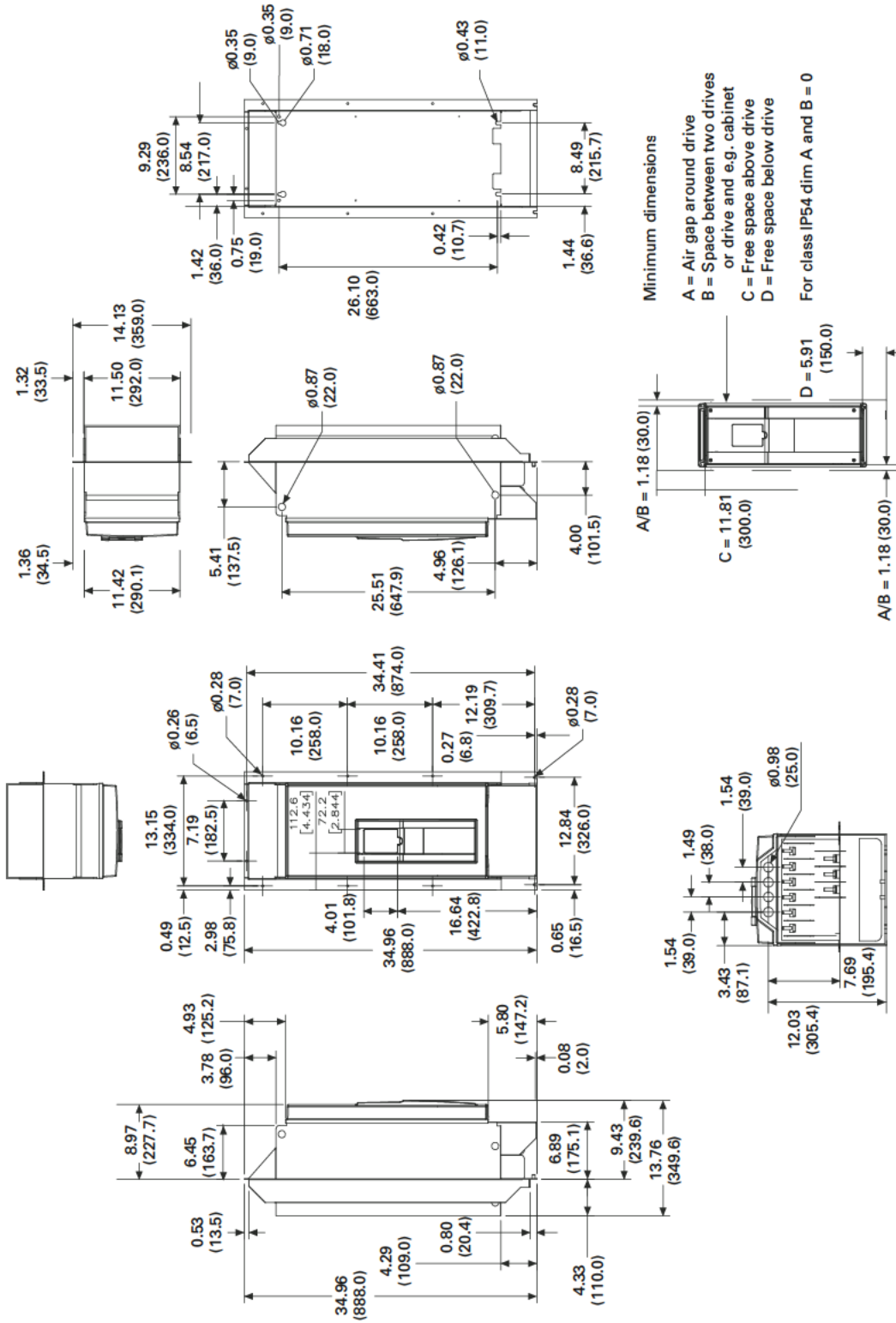

Minimum dimensions

- A = Air gap around drive
 - B = Space between two drives or drive and e.g. cabinet
 - C = Free space above drive
 - D = Free space below drive
- For class IP54 dim A and B = 0

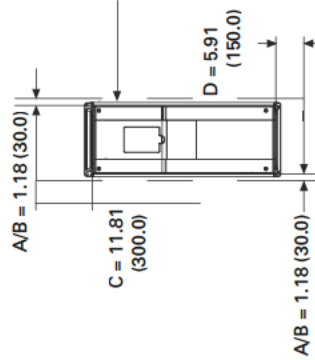

Dimensions = Inches (mm)
 FS8 NEMA Type 1/IP21
 FS8 NEMA Type 12/IP54

Frame size	Voltage	HP (VT)	kW	Amps	Weight Lbs (kg)
8	230 Vac	50-75 HP	37-55	104-205	154 (70)
	460 Vac	100-150 HP	75-110	140-205	154 (70)

FS9 Dimension Drawing

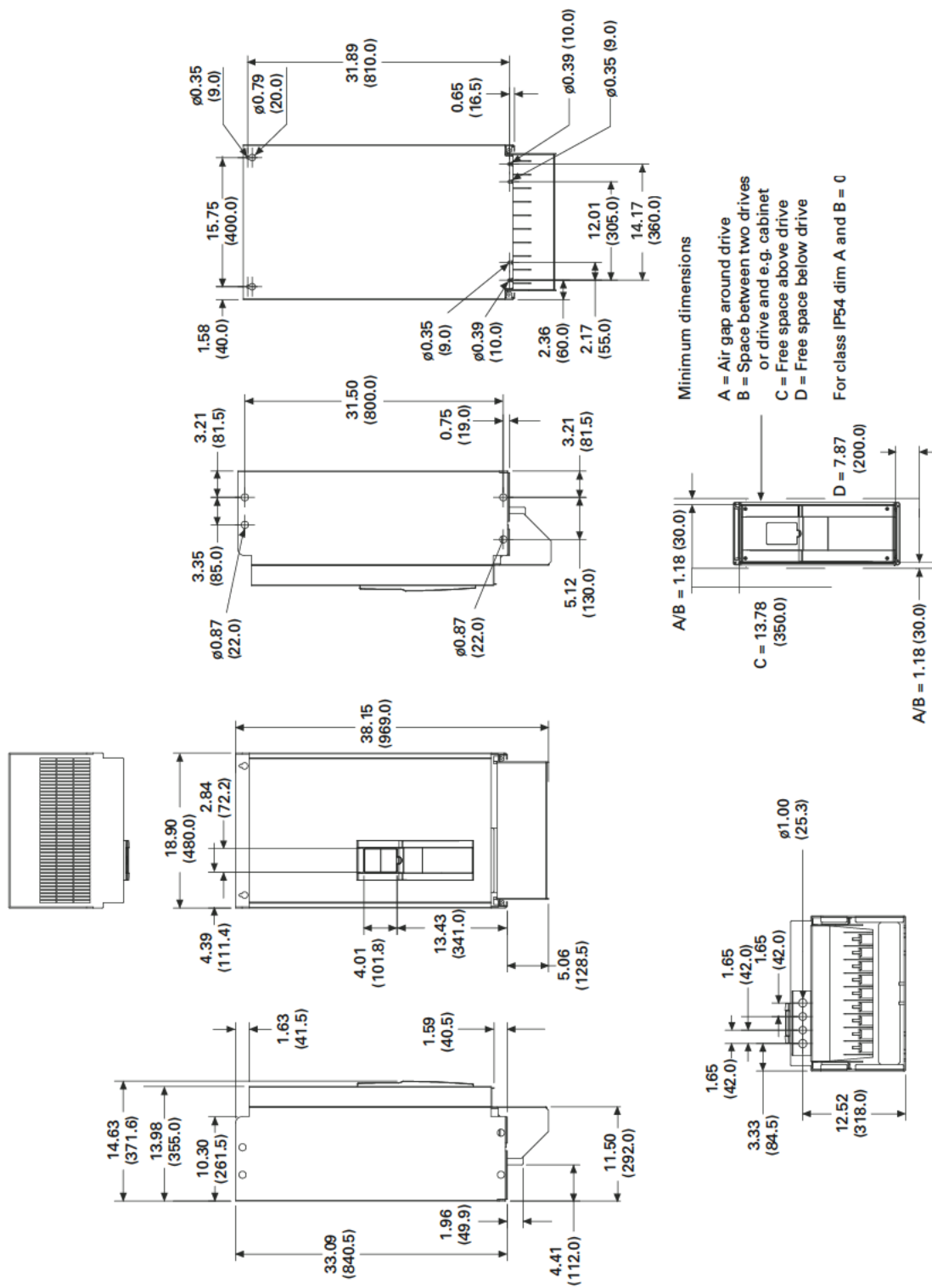

Frame size	Voltage	HP (VT)	kW	Amps	Weight
	230 Vac	100-125 HP	75-90	261-310	Lbs (kg)
9	460 Vac	200-250 HP	132-160	261-310	238.1 (108)
					238.1 (108)

FS9 Dimension Drawing Flange Mount

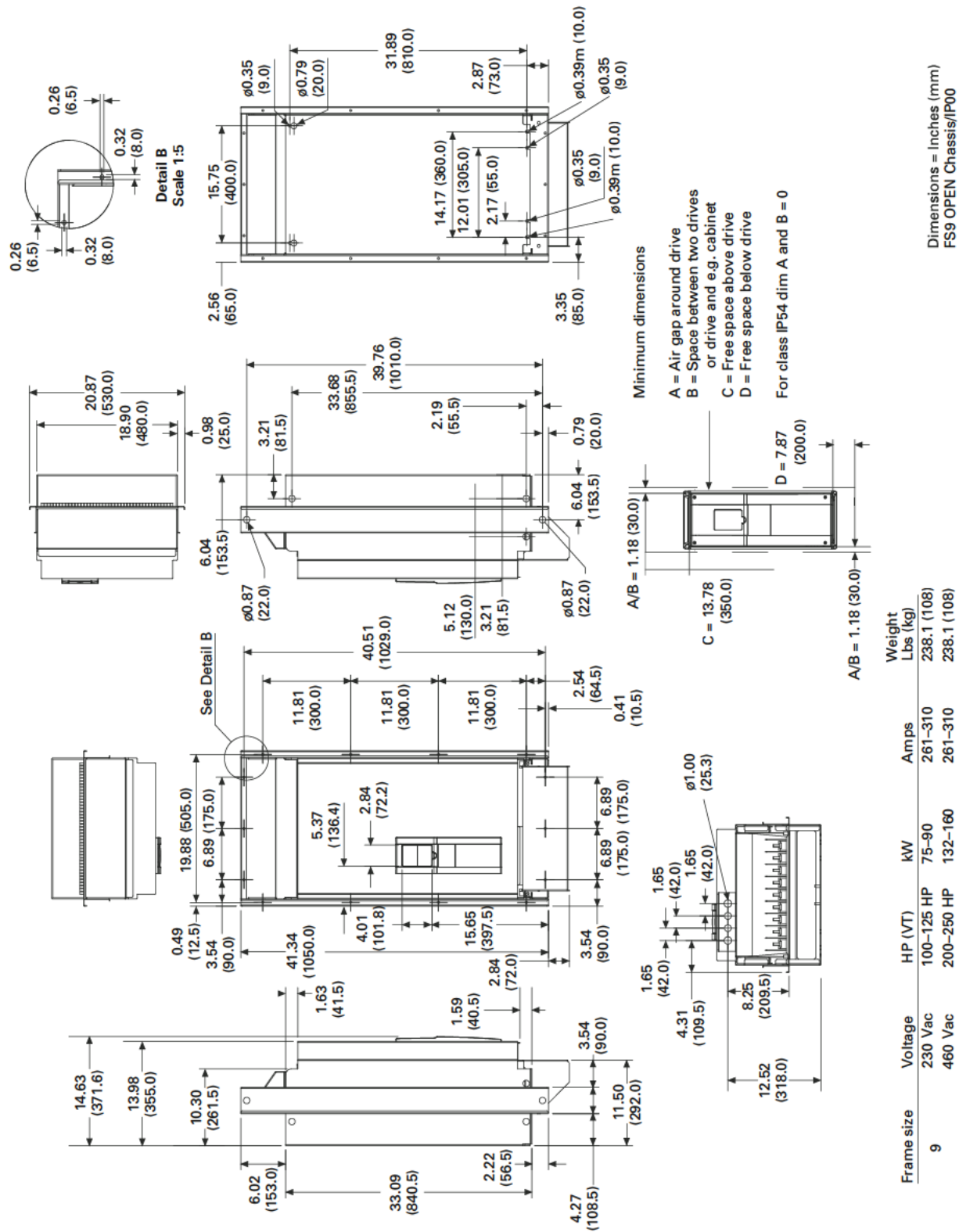

Document ID:



Eaton is a registered trademark
of Eaton Corporation.

All other trademarks are property
of their respective owners.

H-Max Series Drives

H-Max Series Drives IntelliPass® / IntelliDisconnect® Frames 4-7



EATON

Powering Business Worldwide

Important Notice – Please Read

Important Notice – Please Read

The product discussed in this literature is subject to terms and conditions outlined in Eaton Electrical Inc. selling policies. The sole source governing the rights and remedies of any purchaser of this equipment is the relevant Eaton Electrical Inc. selling policy.

NO WARRANTIES, EXPRESS OR IMPLIED, INCLUDING WARRANTIES OF FITNESS FOR A PARTICULAR PURPOSE OR MERCHANTABILITY, OR WARRANTIES ARISING FROM COURSE OF DEALING OR USAGE OF TRADE, ARE MADE REGARDING THE INFORMATION, RECOMMENDATIONS AND DESCRIPTIONS CONTAINED HEREIN.

In no event will Eaton Electrical Inc. be responsible to the purchaser or user in contract, in tort (including negligence), strict liability or otherwise for any special, indirect, incidental or consequential damage or loss whatsoever, including but not limited to damage or loss of use of equipment, plant or power system, cost of capital, loss of power, additional expenses in the use of existing power facilities, or claims against the purchaser or user by its customers resulting from the use of the information, recommendations and descriptions contained herein. The information contained in this manual is subject to change without notice.

Safety

Read and follow all safety information shown in the H-Max installation Manual MN04008005E.

Contents

INTRODUCTION

General	4
Catalog / Style Numbering	4

IDENTIFICATION

Unit ID labels	5
Components	7

FACTORY WIRED OPTIONS

P3-Drives Isolation Fuses	9
P6-Drives Isolation Contactor includes Drive test Switch	11
IS-Isolation Switch	12
M1-Manual Bypass (forced) Switch	13
PE-Drive Output contactor	14
SA - Space Heater Option	14
L3/L4-HMAX Pilot Lights	16

PLUG IN OPTIONS

K9 Aux Contacts	17
Optional plug in PCBS	18

DIMENSIONS AND MOUNTING

WIRING

Schematic	26
Conduit plates	33
Input Power wiring	34
Motor wiring	36
Ground Wiring	39
Control wiring	40

INITIAL POWER UP - INTELLIPASS AND INTELLIDISCONNECT

INTELLIDISCONNECT OPERATION (STARTING / STOPPING OF THE MOTOR)

INTELLIPASS OPERATION (STARTING / STOPPING OF THE MOTOR)

Drive Mode	41
Bypass Mode	41
HOA Control - IntelliPass	43
Key Parameters related to proper IntelliPass Bypass operation	44

INTELLIPASS/INTELLIDISCONNECT TECHNICAL INFORMATION

General

General

This document provides supplement information to the H-Max installation Manual MN04008005E specific to the H-Max IntelliPass and IntelliDisconnect products. These products are offered with input/output voltages of 208, 230 & 480 VAC with HP ranges from 1 to 75hp. Both UL Type 1,12 and Type 3R enclosures are available along with several factory wired power and plug in options.

Catalog/Style Numbering

Eaton HMAX IntelliPass and IntelliDisconnect Catalog Number Matrix

Product:	Enclosure/Style:	Voltage:	Braking:	Intellipass/Options:	Intellidiscconnect Options:
<p>HMX = HVAC Drive (VT)</p>	<p>3 = IntelliPass NEMA Type 1 4 = IntelliPass NEMA Type 12 5 = IntelliPass NEMA Type 3R A = IntelliDisconnect NEMA Type 1 B = IntelliDisconnect NEMA Type 12 C = IntelliDisconnect NEMA Type 3R</p>	<p>1 = 208V 2 = 230V 4 = 480V 5 = 575V</p>	<p>N = No Brake Chopper (Low Overload) B = Internal Brake Chopper Low</p>	<p>00 = None P3 = Drive Isolation Fuses (for FS 4-7 not available with M1, P6 or PE options) P6 = Drive Isolation Contactor includes drive test switch (For FS 4-7 not available with M1, P3 or PE options) L4 = Pilot Lights (not available with M1) M1 = Manual Bypass - includes pilot lights and Isolation contactor (not available with any other wired option) IS = Isolation Switch not available with M1, P6 or PE options SA = Space Heater w/Xformer (Type 3R only) K9 = Aux Contacts</p>	<p>00 = None P3 = Drive Isolation Fuses PE = Drive Output contactor L3 = HMAX Pilot Lights SA = Space Heater w/Xformer (Type 3R only) K9 = Aux Contacts</p>
<p>HMX 011 3 4 N A P3</p>			<p>Software Options: A - Standard</p>		
<p>Intellidiscconnect Options: 00 = None B1 = 6 DI or DO, 1 ext +24V DC/EXT +24V DC Programmable B2 = 1 RO (NC/NO), 1 RO (NO), 1 Thermistor B4 = 1 AI (mA isolated), 2 AO (mA isolated) B5 = Card-3 Relay Dry Contact B9 = 1 RO (NO), 5 DI 42 – 240V AC Input BF = Expander IO - 1*AO, 1*DO, 1*RO</p>	<p>Extended I/O Options in Slot D & E: B1 = 6 DI or DO, 1 ext +24V DC/EXT +24V DC Programmable B2 = 1 RO (NC/NO), 1 RO (NO), 1 Thermistor B4 = 1 AI (mA isolated), 2 AO (mA isolated) B5 = Card-3 Relay Dry Contact B9 = 1 RO (NO), 5 DI 42 – 240V AC Input BF = Expander IO - 1*AO, 1*DO, 1*RO</p>		<p>I/O Options in Slot B F2 = 2 relay and 1 Thermistor- not available with L3/L4 Pilot light option replaces standard Relay1 pcb in Slot B and Fault Relay function</p>		
<p>Optional Communications in Slot D & E: C4 = OPTC4: Lonworks</p>			<p>On Board Base RS485 Communications: BACnet MS/TP = MS/TP = Master Slave / Token Protocol (Universal BACnet) RS 485 ModbusRTU RS485, ASCII or RTU, remote terminal unit 32 Nodes</p>		
<p>Notes: All Boards are Varnished Battery Included in all drives for real time clock EMC = EMC C2 Standard Graphic keypad on all drives Bypass & HOA Keypad</p>			<p>On Board Ethernet Based Communications: BACnet/IP Ethernet Industrial Protocol M = Modbus/TCP Transmission Control Protocol (Ethernet Based) Note All Boards are Varnished</p>		
<p>NEC 208 Volts: 4D6 = 4.6 Amp = 1.0 HP 7D5 = 7.5 Amp = 2 HP 011 = 11 Amp = 3 HP 017 = 17 Amp = 5 HP 025 = 24 Amp = 7.5 HP 031 = 31 Amp = 10 HP 047 = 47 Amp = 15 HP 060 = 60 Amp = 20 HP 075 = 75 Amp = 25 HP 088 = 88 Amp = 30 HP</p>	<p>NEC 230 Volts: 4D2 = 4.2 Amp = 1.0 HP 6D8 = 6.8 Amp = 2 HP 9D6 = 9.6 Amp = 3 HP 016 = 16 Amp = 5 HP 022 = 22 Amp = 7.5 HP 028 = 28 Amp = 10 HP 042 = 42 Amp = 15 HP 054 = 54 Amp = 20 HP 068 = 68 Amp = 25 HP 080 = 80 Amp = 30 HP 104 = 104 Amp = 40 HP</p>	<p>NEC 480 Volts: 2D1 = 2.1 Amp = 1 HP 3D4 = 3.4 Amp = 2 HP 5D6 = 5.6 Amp = 3 HP 7D6 = 7.6 Amp = 5 HP 011 = 11 Amp = 7.5 HP 014 = 14 Amp = 10 HP 021 = 21 Amp = 15 HP 027 = 27 Amp = 20HP 034 = 34 Amp = 25 HP 040 = 40 Amp = 30 HP 052 = 52 Amp = 40 HP 065 = 65 Amp = 50 HP 077 = 77 Amp = 60 HP 096 = 96 Amp = 75 HP</p>			

Identification

Unit ID labels

H-Max IntelliPass/IntelliDisconnect Carton Label

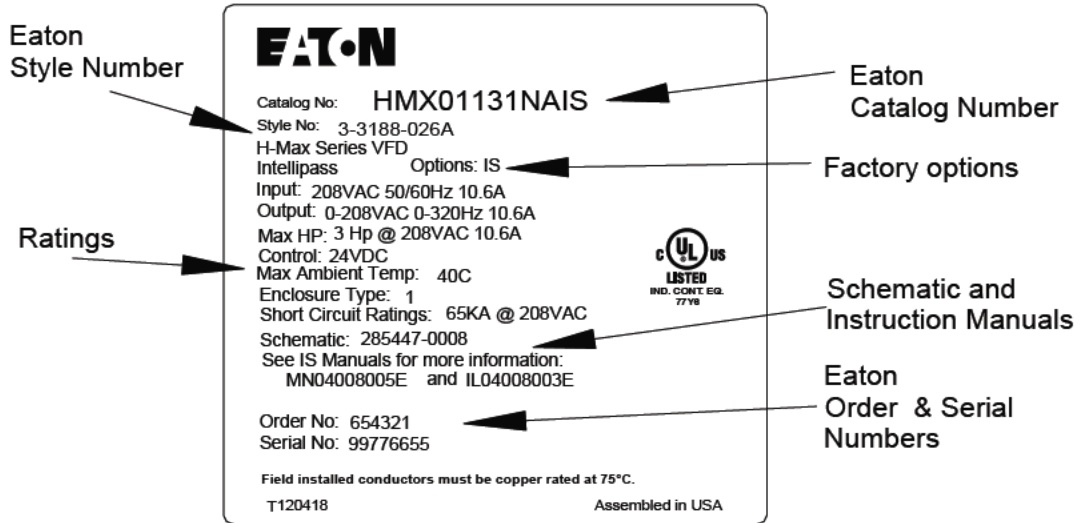

H-Max IntelliPass/IntelliDisconnect Nameplate

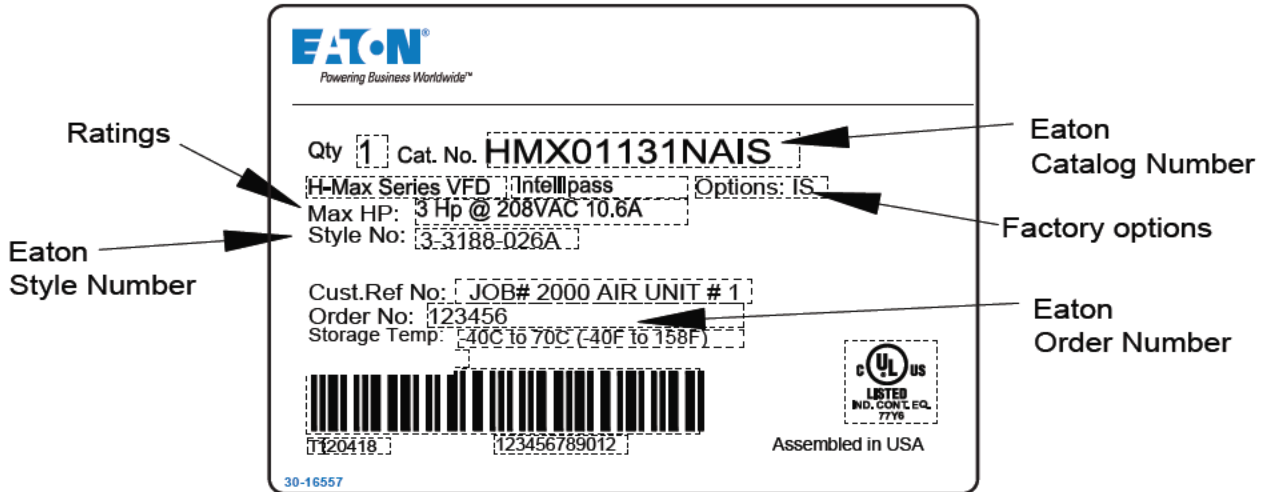

Identification

Use table below to determine enclosure size and frame size based on Hp.

Enclosure Size and drive Frame size Identification

Volts	Hp	Current	Drive Size	Standard Enclosure Type 1/12	3R and Oversize Enclosure type 1/12		
208	1	4.6					
	2	7.5					
	3	10.6					
230	1	4.2	4	Size 4			
	2	6.8					
	3	9.6					
480Y/277	1	2.1					
	2	3.4					
	3	4.8					
	5	7.6					
	7.5	11				A	
208	5	16.7					
	7.5	24.2					
	10	30.8					
230	5	15.2	5	Size 5			
	7.5	22					
	10	28					
480Y/277	10	14					
	15	21					
	20	27					
208	15	46.2					
230	15	42					
480Y/277	25	34				6	Size 6
	30	40					
	40	52					
208	20	59.4	6				
	25	74.8	7				
	30	88					
230	20	54	6				
	25	68					
	30	80				Size 7	C
	40	104					
480	50	65	7				
	60	77					
	75	96					

Components

IPass and IDisc Typical Component locations.

Typical Component Locations

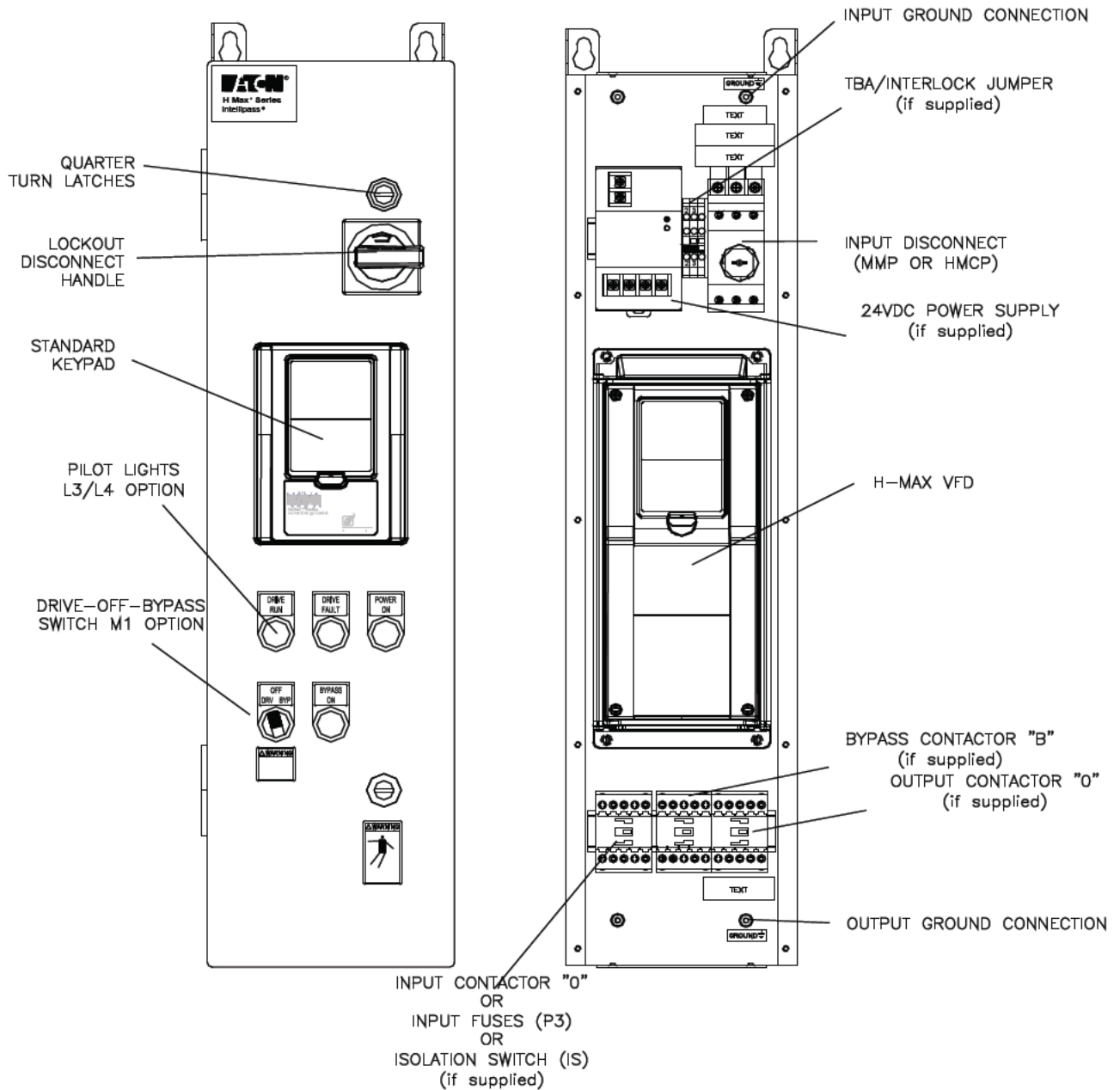

Identification

Components

IPass and IDisc Typical Component locations.



Factory Wired Options

The IntelliPass and IntelliDisconnect can be supplied with several factory wired power options. The sections below describe the options.

Options

HMAX Option Matrix	IPass	IDisc
P3 - Drive Isolation Fuses	X	X
P6 - Drive Isolation Contactor includes manual switch	X	N/A
PE - Drive Output contactor	N/A	X
IS - Isolation Switch	X	N/A
SA - Space Heater (3R only)	X	X
K9 - Aux Contacts	X	X
M1 - Manual Bypass includes L4 and drive isolation contactor and door switch	X	N/A
L3 - H-Max Pilot Lights	N/A	X
L4 - H-Max Pilot Lights	X	N/A

P3- Drive Isolation Fuses

This option is available for both the IntelliPass and IntelliDisconnect designs 208/230V up to 30Hp and 480V models up to 75 hp.

3 Power Fuses are supplied wired to the Drive input. They are provided between the disconnect device and drive. The fuses are not used in the bypass mode. The fuses are for drive protection only. They are listed, Class CC or Special Purpose Fuse cube fuses sized according to the following table. This option cannot be used with IS Isolation switch or P6 isolation contactor options. See IntelliDisconnect or Typical IntelliPass schematic.

Hp Rating and Fuse Rating (A)

HP	208 V Fuse	230 V Fuse	460 V Fuse
1	6	6	5
2	12	12	6
3	20	20	8
5	25	25	12
7.5	30	30	20
10	45	45	25
15	60	60	30
20	80	80	45
25	90	90	45
30	100	100	50
40	N/A	N/A	60
50	N/A	N/A	80
60	N/A	N/A	90
75	N/A	N/A	100

Factory Wired Options

P3 Drive Fuse Option

TYPICAL VIEW FRAMES 4-6 (FR4 SHOWN)

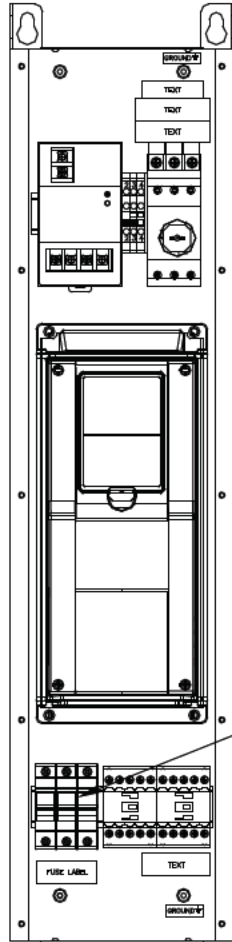

TYPICAL VIEW FRAME 7

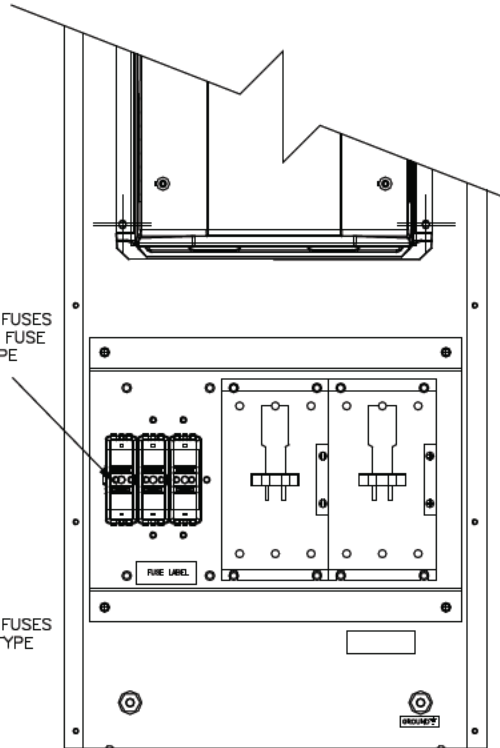

DRIVE FUSES
CUBE FUSE
TYPE

DRIVE FUSES
CC TYPE

44-4429-10 & 11 ONLY

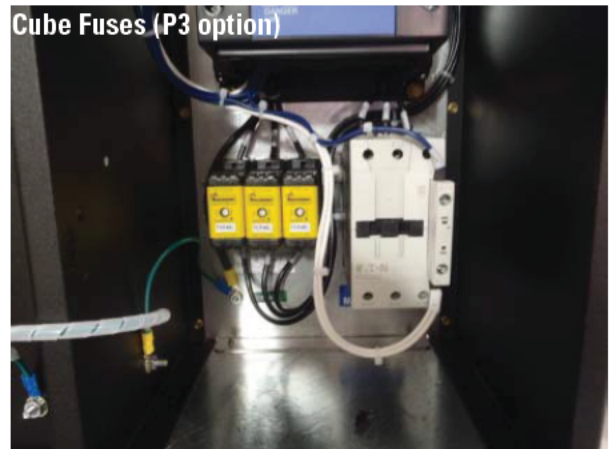
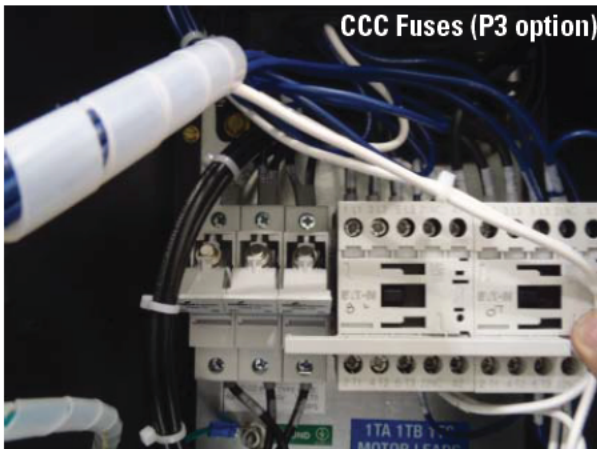

P6 – Drive Isolation Contactor includes Drive test switch

This option is only available on the IntelliPass models. An input contactor is supplied wired to the drive input and a manual 2 position selector switch is provided to control the contactor. The switch is located inside the enclosure on the door. The enclosure door must be opened to operate this switch. See typical IntelliPass schematic.

The contactor removes main power from the Drive. The Drive display and logic will remain active because of the separate 24Volt power supply, but the Drive will not run. The Drive Keypad is still powered and the bypass feature remains operational and the motor can be run in bypass using the keypad. The input contactor "I" is energized at all times while in the drive mode if the door mounted selector switch is in the on position. This option cannot be used with M1 Manual Bypass, IS Isolation switch or P3 fuse options.

P6 Drive Isolation Contactor Option Typical View Frames 4 - 6 (FR4 Shown)

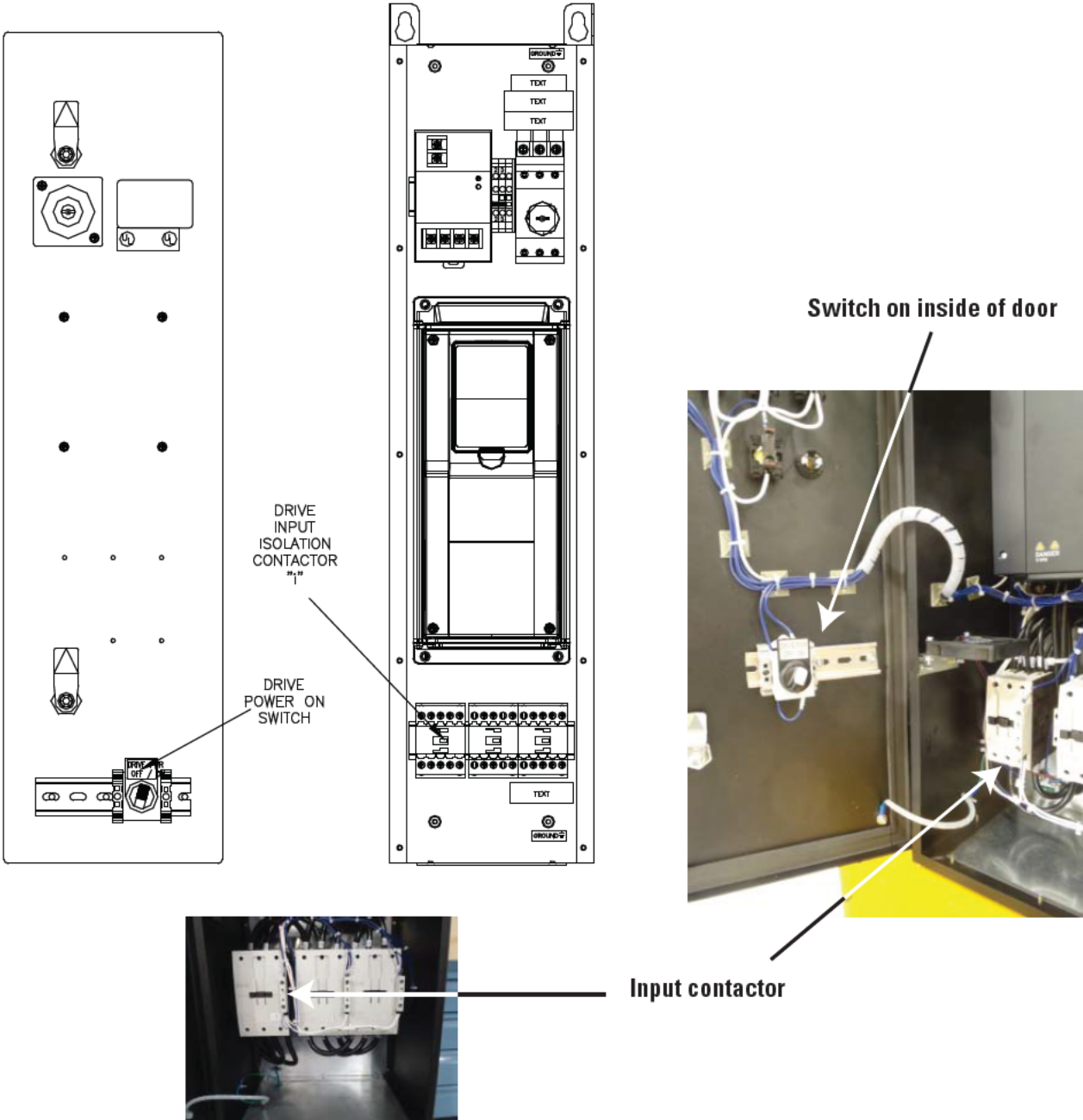

Factory Wired Options

IS - Drive Isolation Switch

This option is available on the IntelliPass models only. This is an MMP or molded case switch, installed at the input of the Drive to be used as a switch only to isolate the drive from input power. The IntelliPass door must be opened to operate this switch – a thru the door operator is not supplied. The switch removes main power from the Drive. The Drive display and logic will remain active because of the separate 24Volt power supply, but the drive will not run. The drive Keypad is still powered and the bypass feature remains operational and the motor can be run in bypass using the keypad. This option cannot be used with P3 or P6 options. See Typical IntelliPass Schematic.

Drive Isolation Switch Option IS

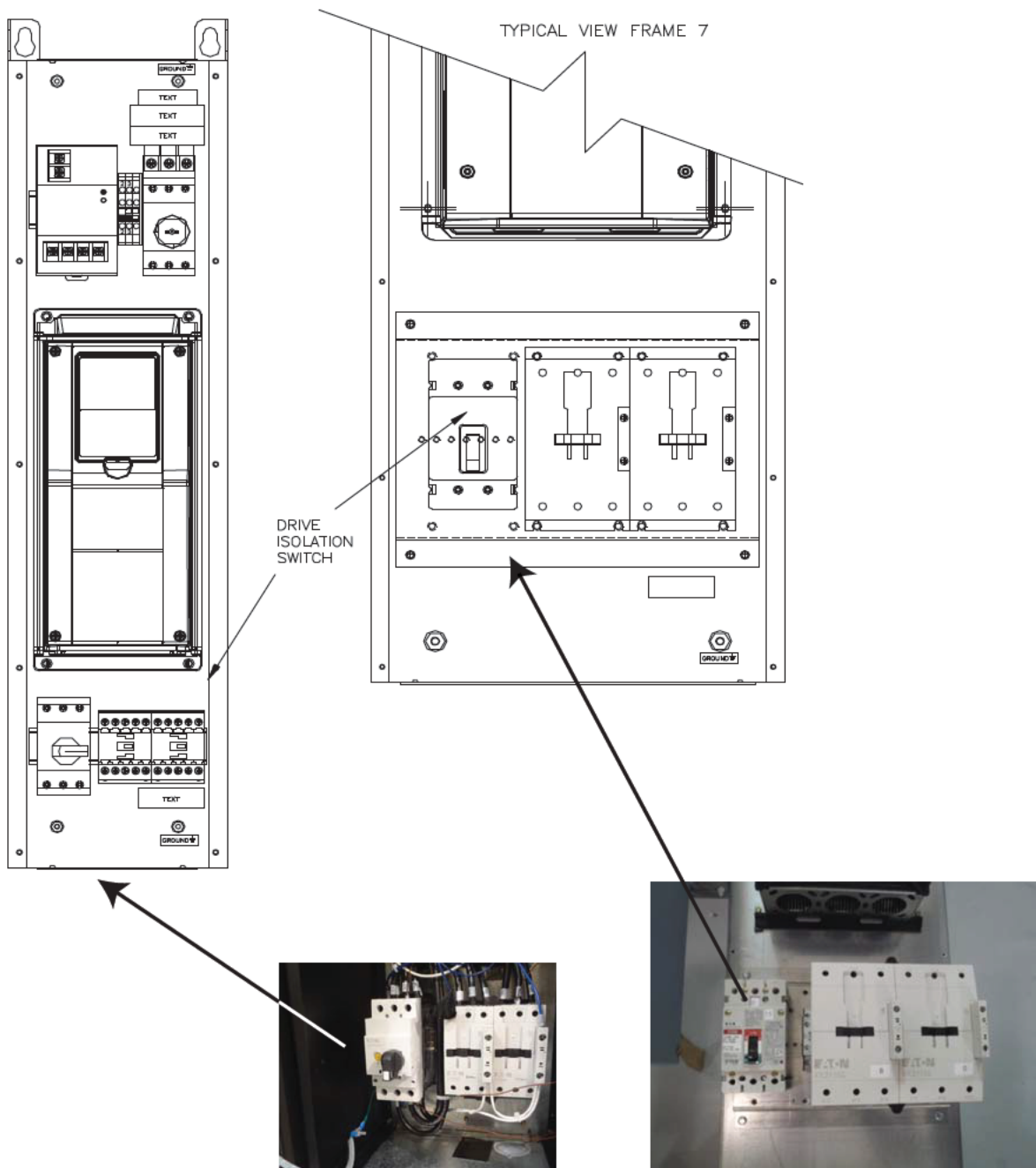

M1 - Manual Bypass (forced) Switch

This option is available on the IntelliPass models only. This option includes an input contactor "I", L4 pilot light option and a 3 position door mounted selector switch - marked Drives/Off/Bypass. This switch manually overrides the Bypass control from the system (keypad) and puts unit in bypass or in an OFF mode. See IntelliPass Schematic with M1 option.

When the door switch is in the Drive position, the H-Max Drive logic controls the motor and the keypad selects the operation (Drive or Bypass), the control source and place (HOA, KEYPAD or Terminal block). The input contactor "I" is energized at all times while in the drive mode.

When the door switch is moved to Bypass, three actions occur: 1) Drive input isolation contactor is forced open, 2) Drive output contactor will be forced open and the bypass contactor will be forced closed. The motor will immediately start and run full speed across the line regardless of the state of the system or drive. 3) The Drive will be forced to the bypass mode and the Keypad Display will show "Bypass". When the switch is moved back the Drive position, Drive operation is restored and the system may need to be restarted.

When the switch is in the off position neither the drive or bypass operation is possible. Moving the Switch to the off or bypass position while the Drive is operating may cause the Drive to fault because the input power to the drive is removed by the input contactor. See L4 for description/operation of the door mounted pilot lights.

Manual Bypass Option M1

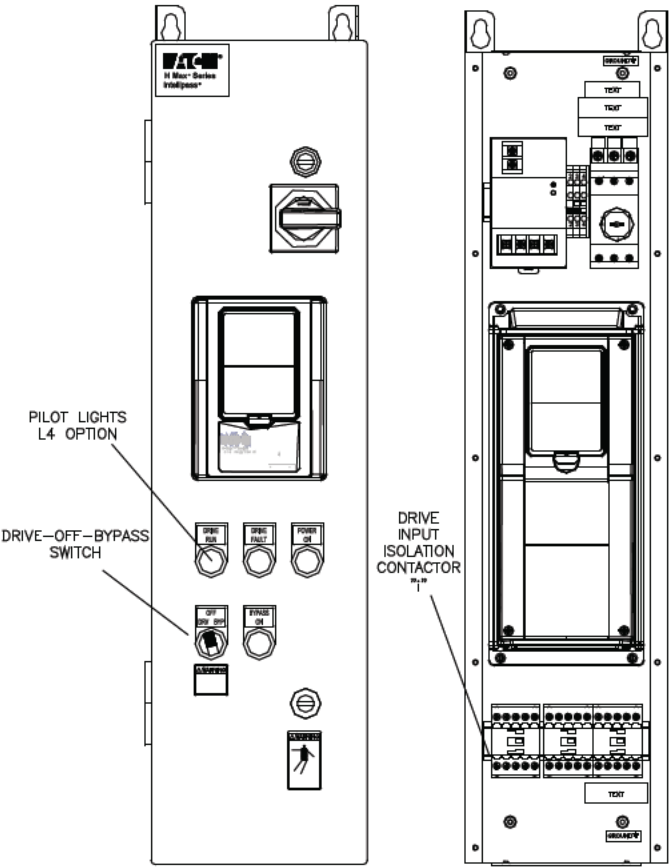

3R Versions have Bypass switch located in Keypad Enclosure



M1 Option

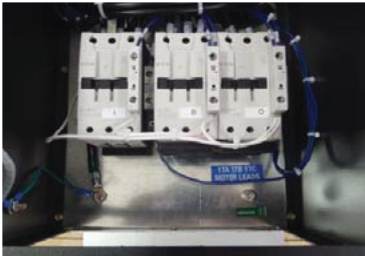

Factory Wired Options

PE- Drive Output contactor

This option is available for IntelliDisconnect models only. This option provides a contactor wired to the Drive output. The motor is then wired to the contactor. The output contactor is controlled by the Drive so when the Drive is stopped the contactor drops out and when the Drive is in a run mode, the output contactor is energized and connects the Drive to the motor. A 24 volt power supply is also provided to power the contactor. Provisions for an external interlock is also provided. See IntelliPass schematic with PE option.

IntelliDisconnect PE Output Contactor Option

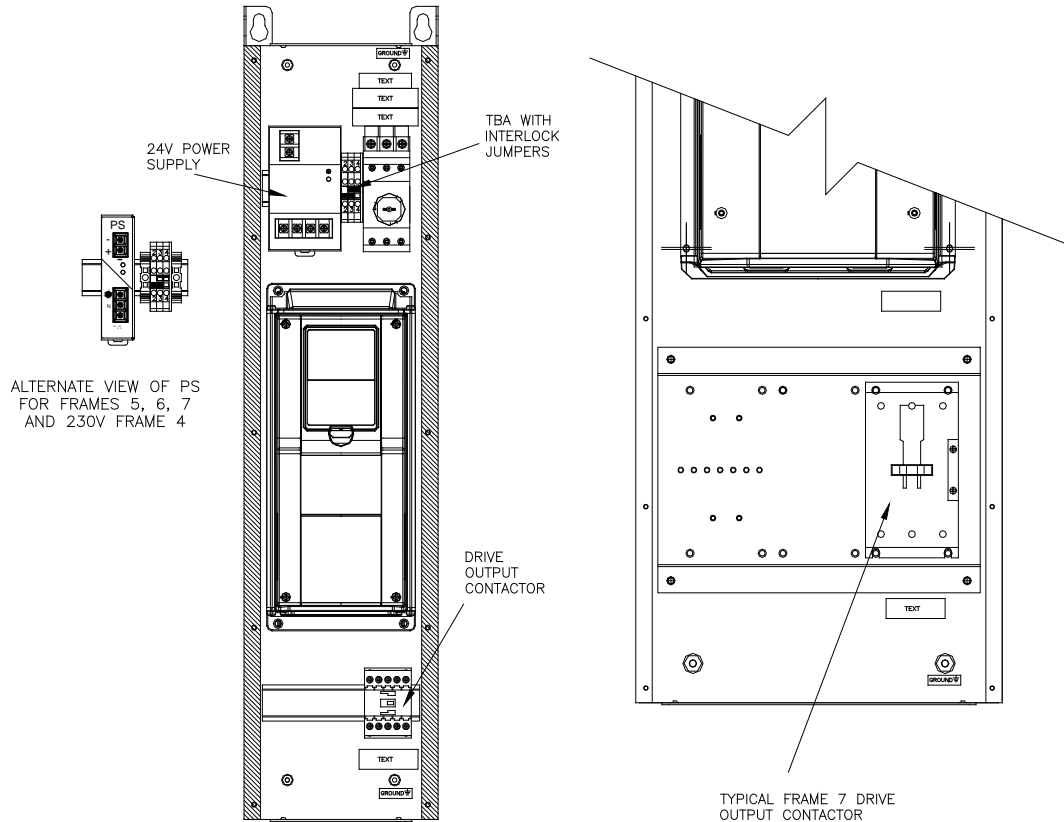

SA - Space Heater Option (Type 3R enclosures only)

This option aids in preventing or reducing condensation from forming in the enclosure when the drive is inactive. A 120V 100W heater is installed in 3R enclosures size A & B and a 200W heater are installed in enclosure size C. A control transformer and fusing is also provided to power the heater. See schematics for more information. The heater includes a user adjustable thermostat for variable temperature control and an internal fan. See pictures

SETTING THE THERMOSTAT

The heater is controlled by an adjustable thermostat. Set the thermostat to the desired temperature. It is recommended not to exceed 75 F for most applications. The heater is active at all times when the main disconnect is closed including when in the Drive, Off or Bypass operation. However, depending on the setting of the thermostat, the internal heat generated by the system when in operation should be enough to turn off the heater. Generally the heater requires no maintenance since the fan bearings are permanently lubricated and sealed.

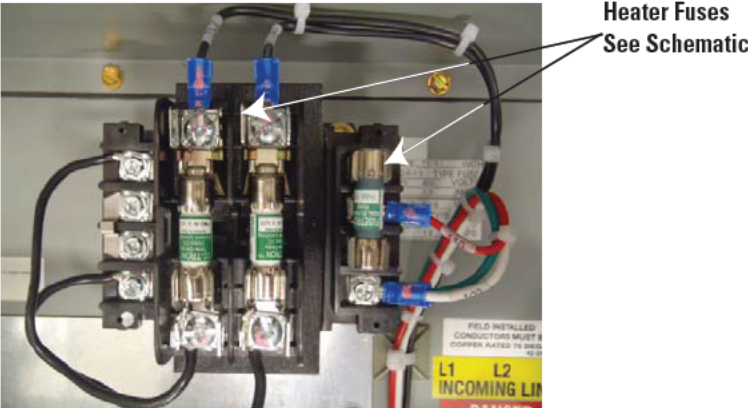
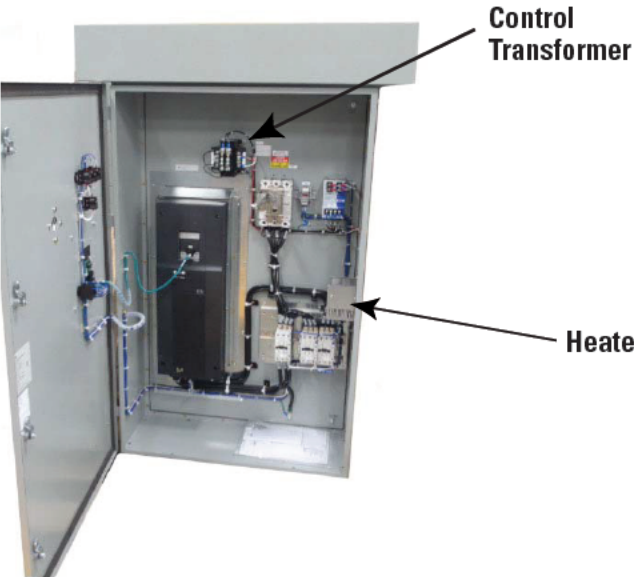

Factory Wired Options

L3/L4 - HMAX Pilot Lights

The L3 option is available only on the IntelliDisconnect models and provides 3 door mounted pilot lights, 1 red, 1 white and 1 green. The L4 option is available on the IntelliPass models and provides 4 door mounted pilot lights: 1 red, 1 white, 1 green and 1 amber.

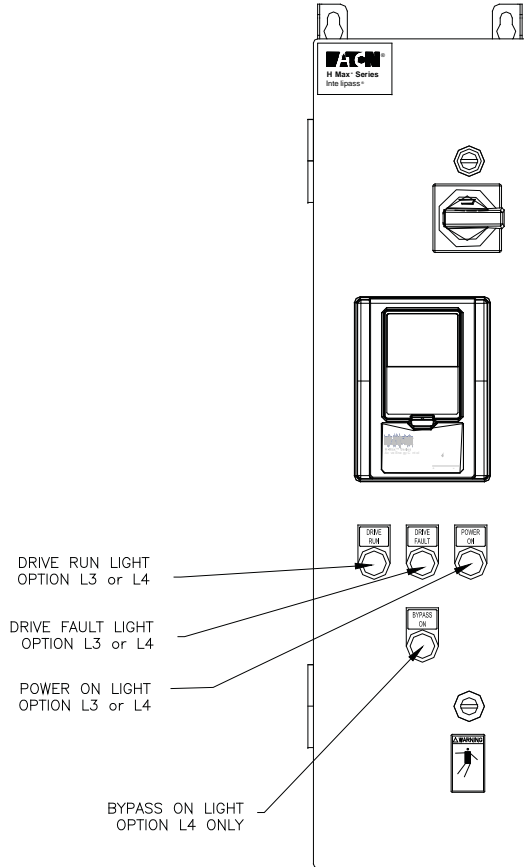

The white "Power On" light indicates that 24VDC power is active. However, Caution is advised if the light is not illuminated, as this is may not be an indication that main power has been removed. If the light fails or the 24V power supply fails, main power may still be present. Always follow proper safety procedures to determine the presence of main power on the unit

The red "Drive Fault" light indicates a Drive fault is present.

The green light indicates the system is commanded to run from the Drive and the Drive is in the "run" mode, the drive output contactor is also energized if the PE option is supplied. The speed of the motor will depend on the Drive speed signal. The motor may not be rotating if commanded at zero speed.

The amber light indicates the system has been commanded to run in bypass. The bypass contactor should be energized and the motor running across the line.

Plug in options

K9 Aux Contacts

This option adds 1 N.O. & N.C. auxiliary contacts to both the Drive output and bypass contactors for customer use.

K9 Aux Contact Applications

Product	Frame	Hp	Voltage	Qty	Eaton P/N	Description
IPass	4	ALL	ALL	2	XTCEXFAC11	Aux NO, NC Contact, B/C frame Top Mount
IPass	5	ALL	ALL	2	XTCEXFAC11	Aux NO, NC Contact, B/C frame Top Mount
IPass	6	ALL	ALL	2	XTCEXFAG11	Aux NO, NC Contact, D/F/G frame Top Mount
IPass	7	ALL	ALL	2	XTCEXFAG11	Aux NO, NC Contact, D/F/G frame Top Mount
IDisc	4	ALL	ALL	1	XTCEXFAC11	Aux NO, NC Contact, B/C frame Top Mount
IDisc	5	ALL	ALL	1	XTCEXFAC11	Aux NO, NC Contact, B/C frame Top Mount
IDisc	6	ALL	ALL	1	XTCEXFAG11	Aux NO, NC Contact, D/F/G frame Top Mount
IDisc	7	ALL	ALL	1	XTCEXFAG11	Aux NO, NC Contact, D/F/G frame Top Mount

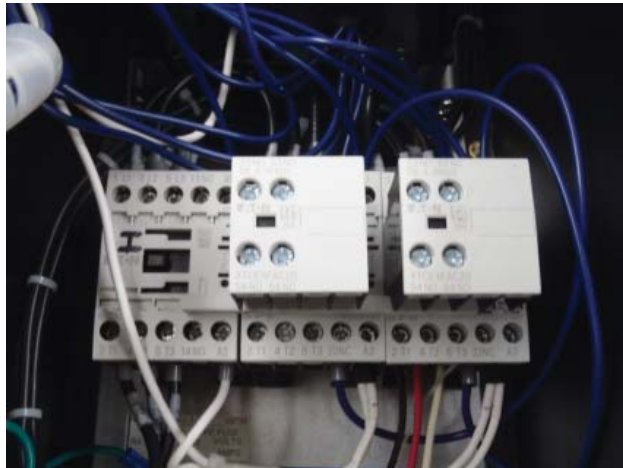

Dimensions & Mounting

Optional plug in PCBS

A number of plug in option cards are available. A maximum of 2 option cards may be factory installed in the control module slots. Available options are shown in the table below.

Typical Plug in Option PCB



See the option manual included with each PCB for more information.

Also see H-Max Installation manual MN04008005E for more information on control wiring, control board layout and options PCBs.

Option	Brand	Config	VFD Frame	Voltage	HP	Qty	P/N	Style Number	Description
B1	All	All	ALL	ALL	ALL	1	XXM-IO-B1-A	3-3131-0003A	I/O Expander Card, 6 DI/DO, Slot D/E
B2	All	All	ALL	ALL	ALL	1	XXM-IO-B2-A	3-3131-0004A	I/O Expander Card 2 x RO + Thermistor, Slot D/E
B4	All	All	ALL	ALL	ALL	1	XXM-IO-B4-A	3-3131-0005A	I/O Expander Card 1 x AI, 2 x AO (isolated), Slot D/E
B5	All	All	ALL	ALL	ALL	1	XXM-IO-B5-A	3-3131-0006A	I/O Expander Card 3 x RO, Slot D/E
B9	All	All	ALL	ALL	ALL	1	XXM-IO-B9-A	3-3131-0007A	I/O Expander Card 1 x RO, 5 x DI (42-240VAC), Slot D/E
BF	All	All	ALL	ALL	ALL	1	XXM-IO-BF-A	3-3131-0008A	I/O expander Card, 1 x AO, 1 x DO, 1 x RO, Slot D/E
C4	All	All	ALL	ALL	ALL	1	XXM-COM-C4-A	3-3131-0009A	LonWorks, Slot D/E

See option manual included with each PCB for more information also see H-Max Installation manual MN04008005E for more information on control wiring and control board layout and options PCBs.

Dimensions & Mounting

The IntelliPass/IntelliDisconnect physical dims are based on the Enclosure frame size. See Table to determine the enclosure frame size based on Hp and voltage.

- Weights and lifting provisions are on the dimension section and with the drawing provided with the unit
- Attach “load-rated” hooks or shackles to lifting eyes on back panel.
- Always maintain a maximum of 45 degrees between the lifting cables and the vertical plane.
- Do not pass ropes or cables through the lifting eyes as sharp edges may cause excessive wear and possible failure.
- Select or adjust rigging lengths to compensate for unequal weight distribution of the load to keep unit in the upright position.

STANDARD ENCLOSURE SIZE 4 TYPE 1/12
DIMENSIONS & MOUNTING

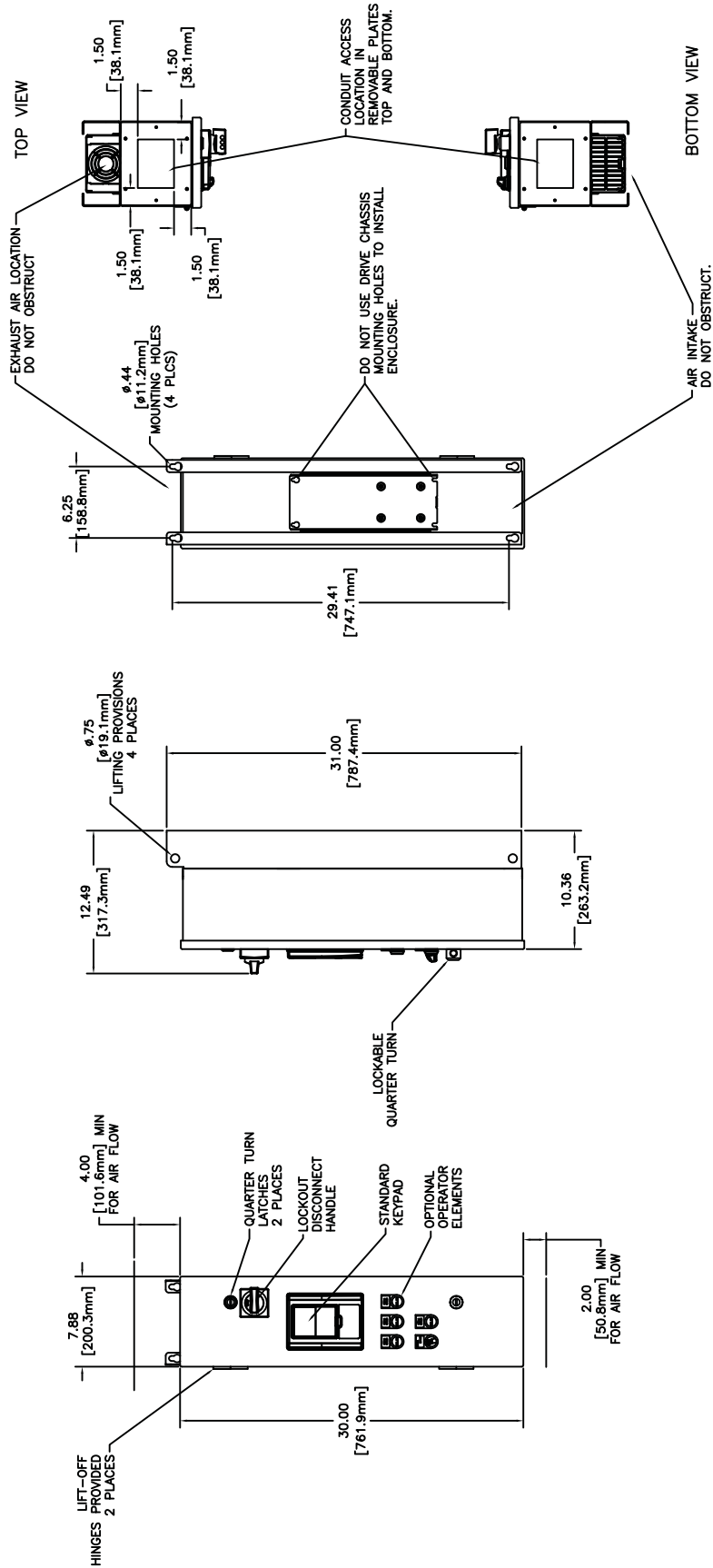

Dimensions & Mounting

STANDARD ENCLOSURE SIZE 5 TYPE 1/12 DIMENSIONS & MOUNTING

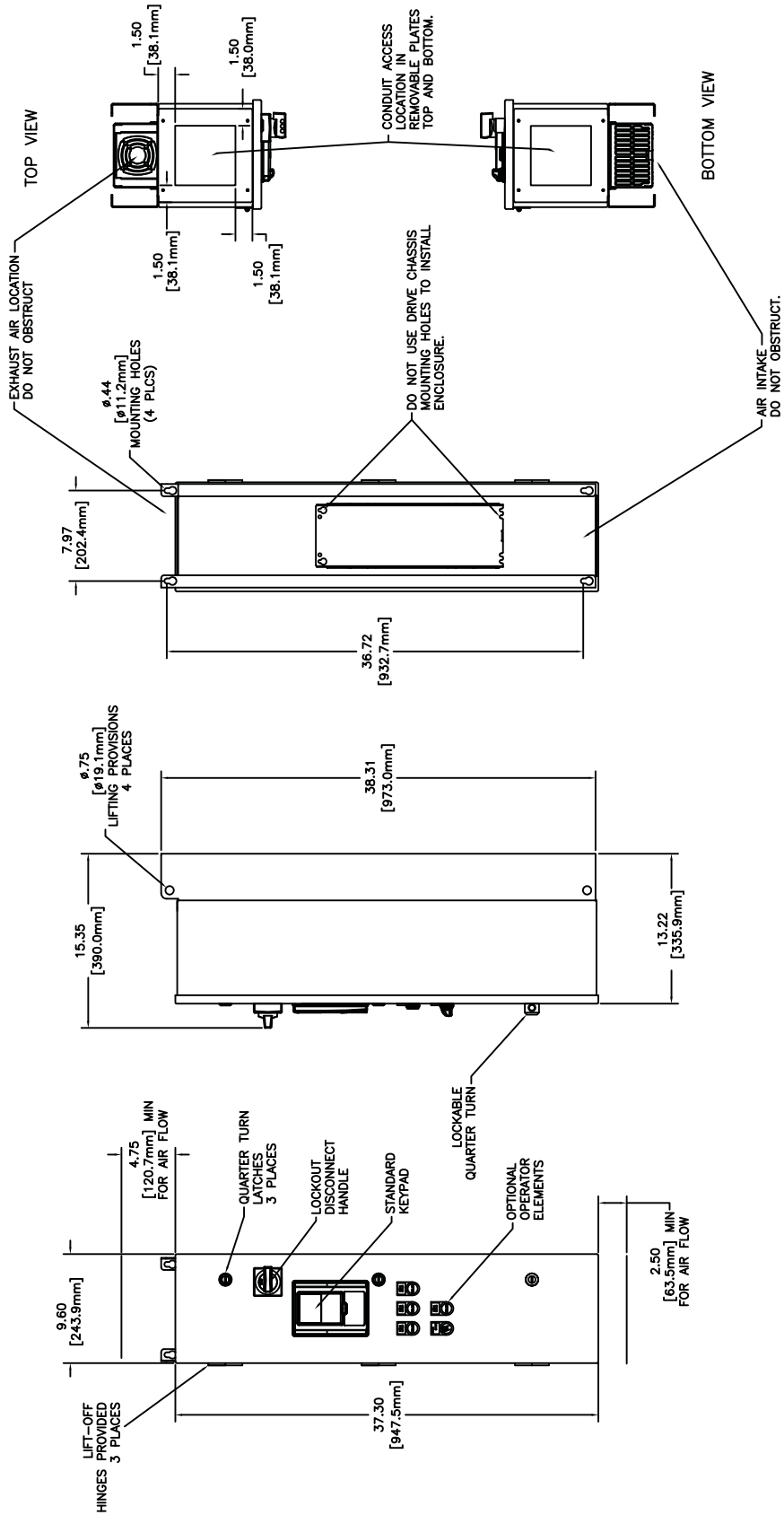

STANDARD ENCLOSURE SIZE 6 TYPE 1/12
DIMENSIONS & MOUNTING

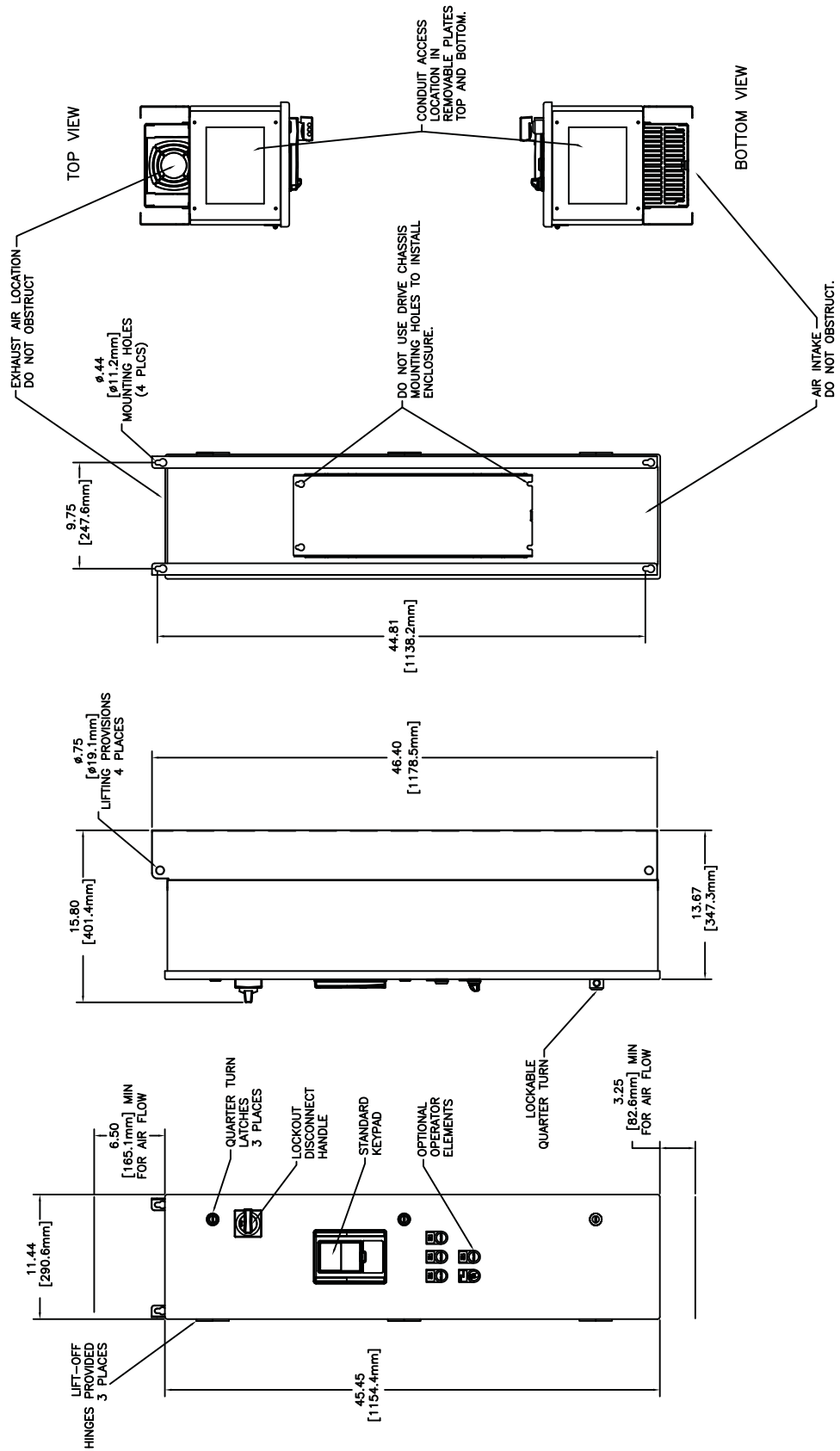

Dimensions & Mounting

STANDARD ENCLOSURE SIZE 7 TYPE 1/12 DIMENSIONS & MOUNTING

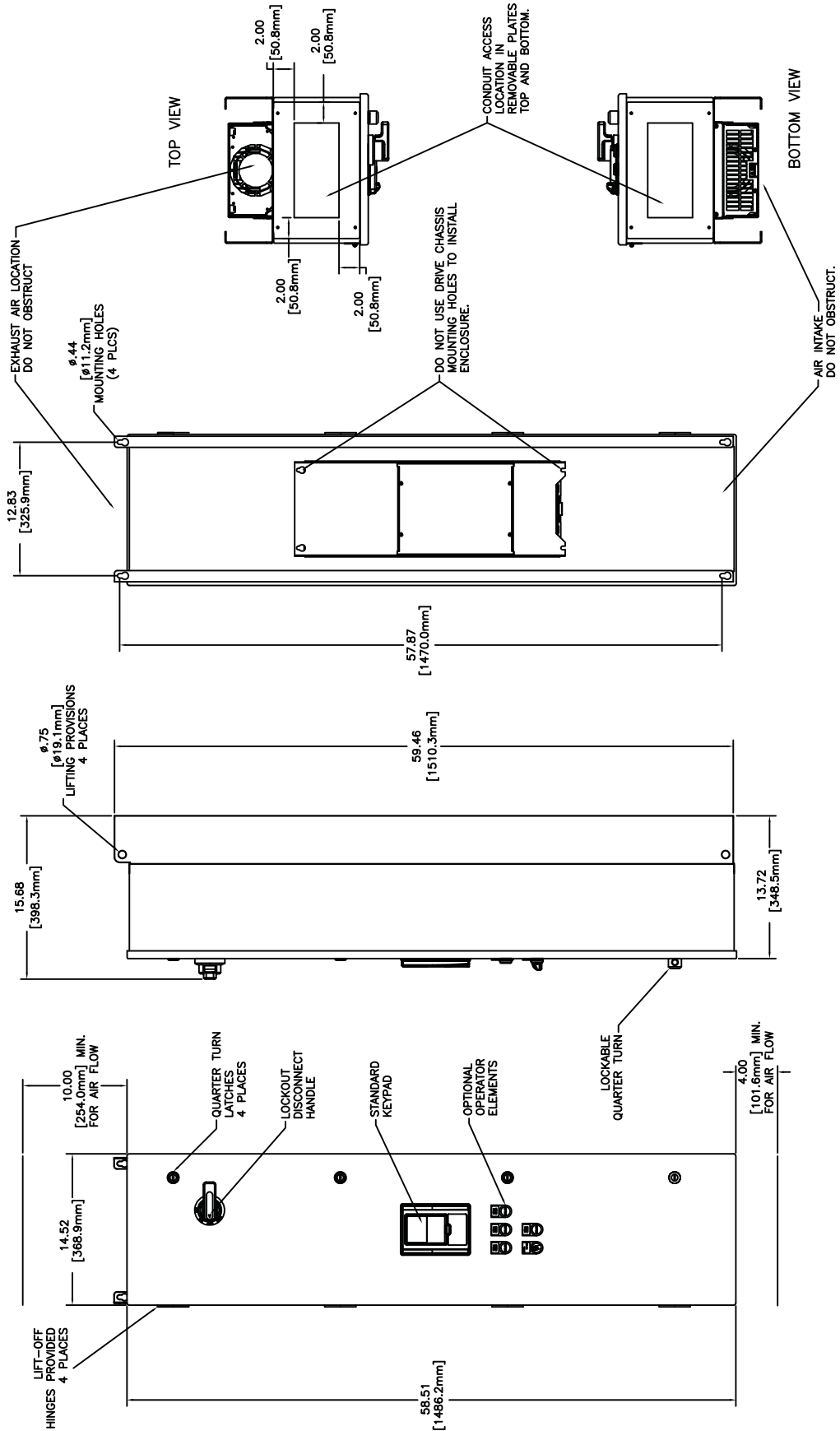

ENCLOSURE SIZE A TYPE 3R / OVERSIZE TYPE 1/12
DIMENSIONS & MOUNTING

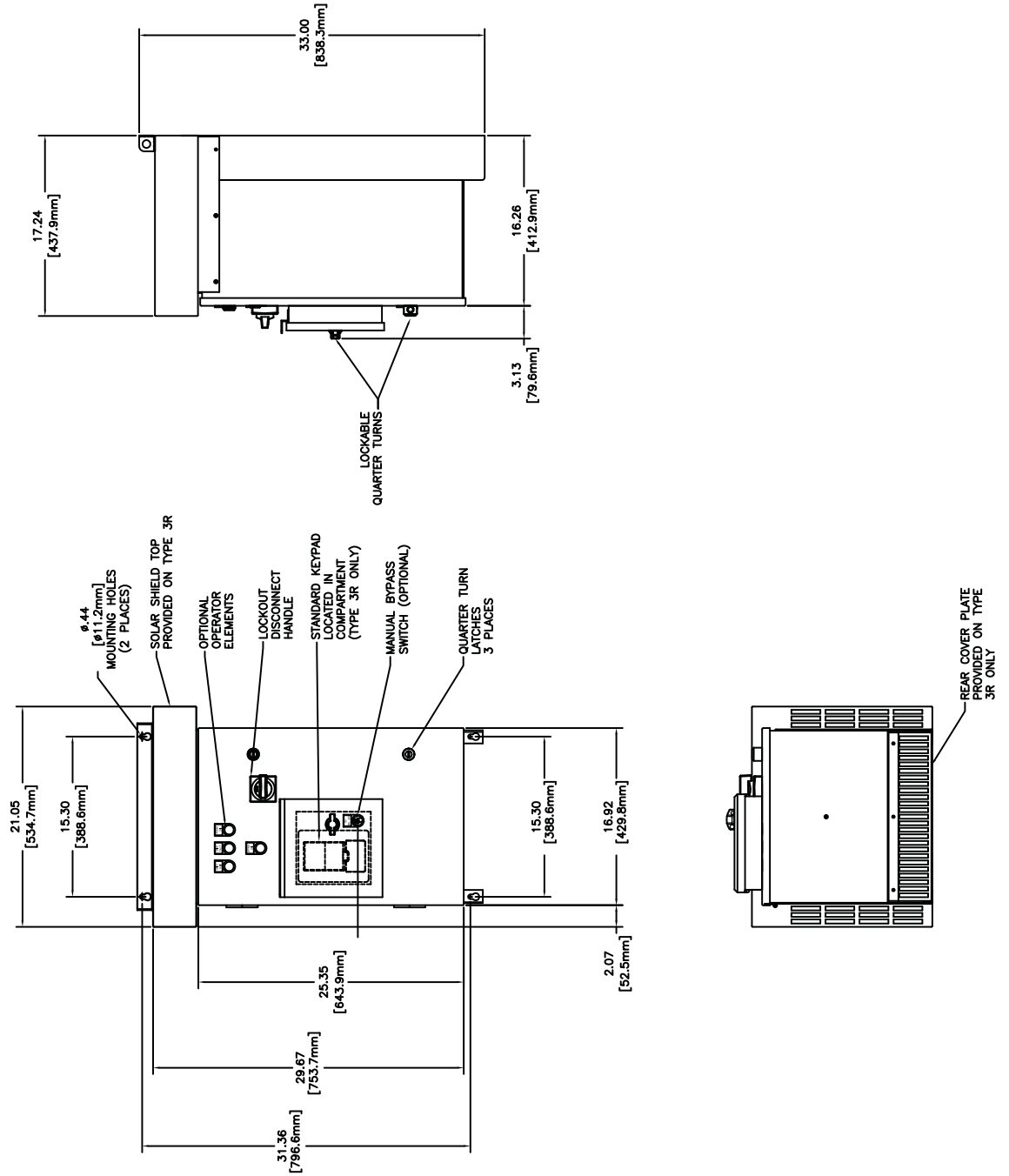

ENCLOSURE SIZE B TYPE 3R / OVERSIZE TYPE 1/12
DIMENSIONS & MOUNTING

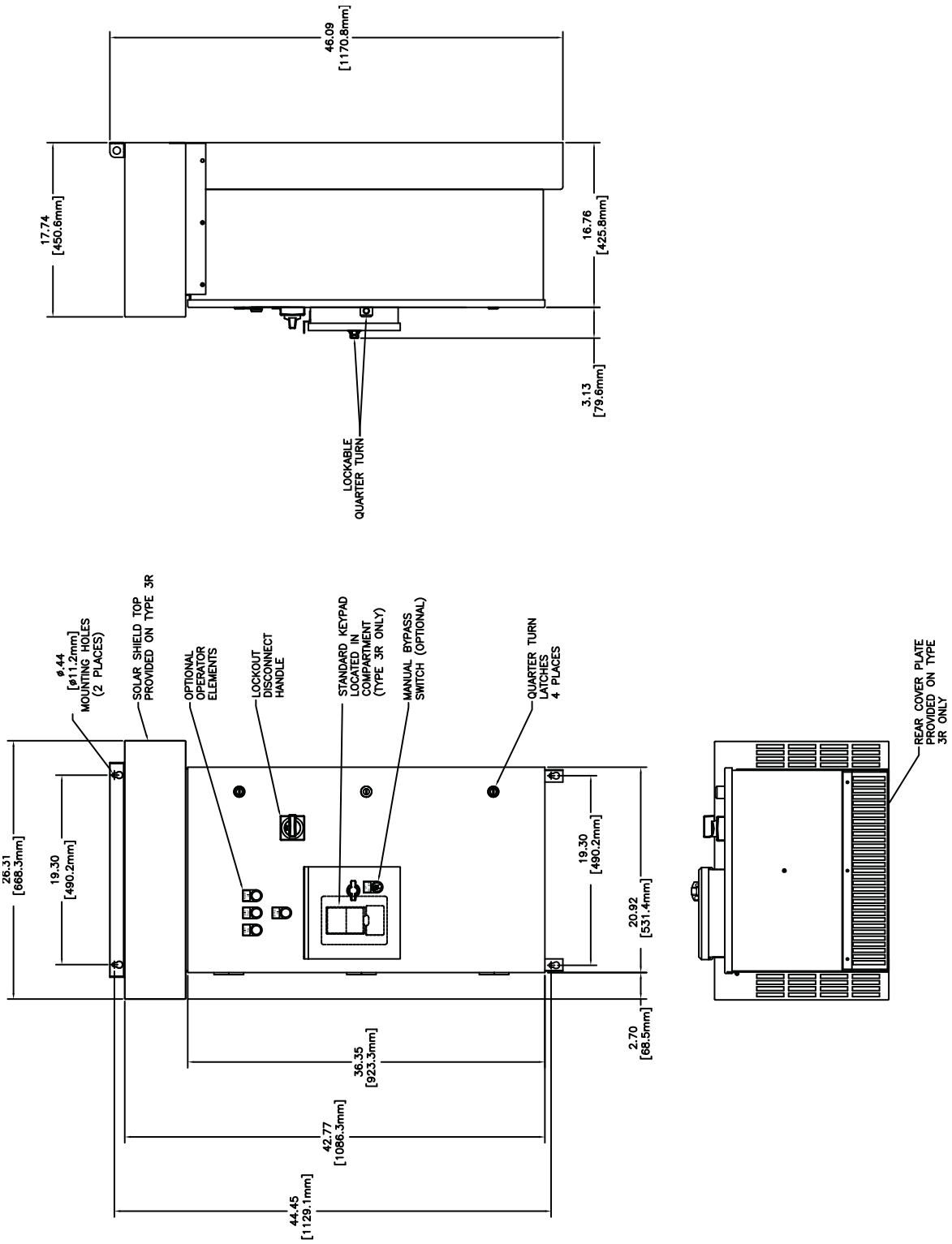

ENCLOSURE SIZE C TYPE 3R / OVERSIZE TYPE 1/12
DIMENSIONS & MOUNTING

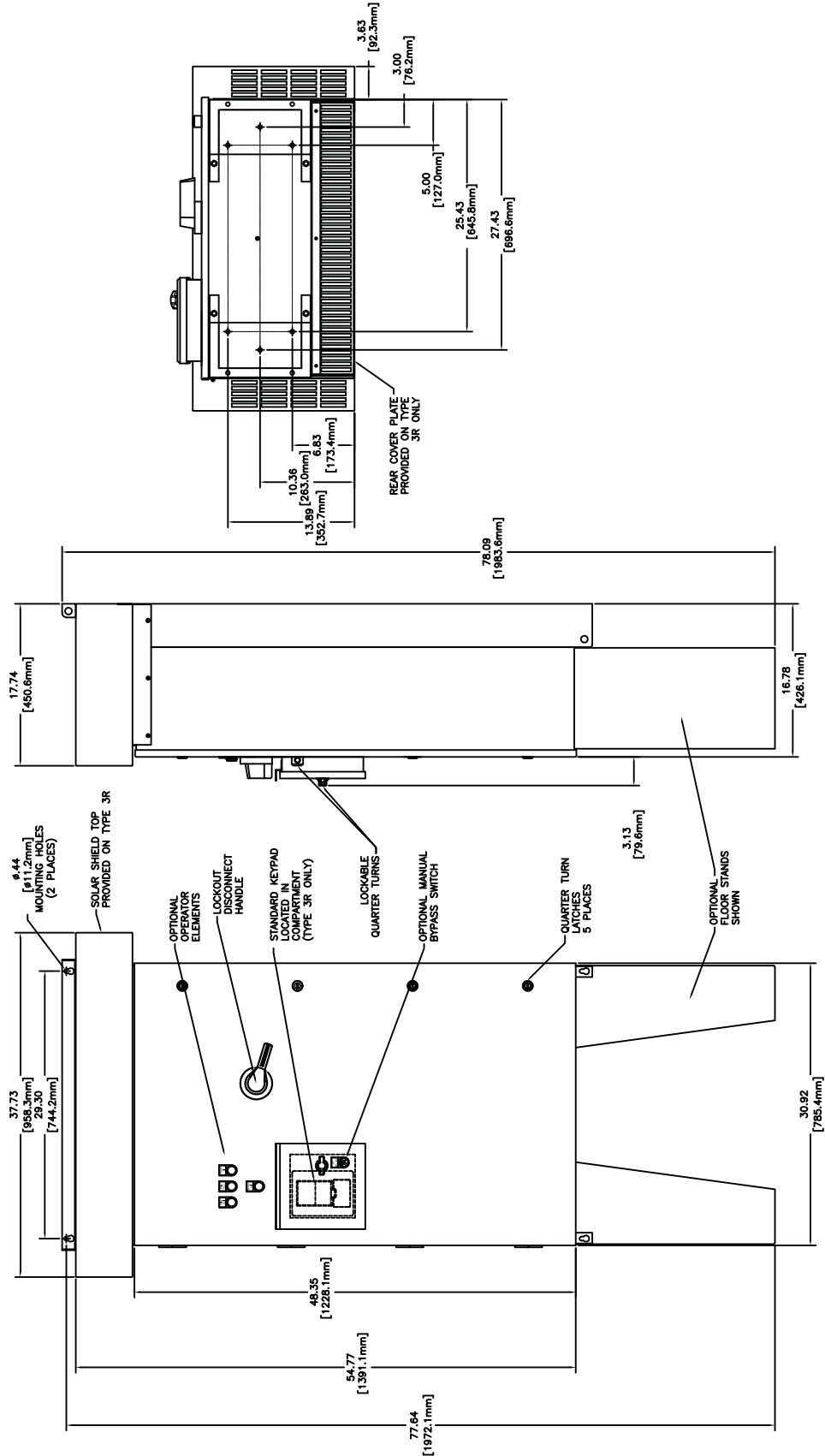

Wiring

Wiring

Schematic

A schematic is included with each product. The schematic number can be found on the product nameplate.

Typical schematics are shown on the next few pages.

NOTE:

Power and Motor Leads must be in separate conduit.

Do not run control wires in same conduit as input power or motor wires

Two grounding points are provided, input ground and output ground

Ground unit properly – improper grounding could damage the unit

IntelliDisconnect Standard - (SA option shown)

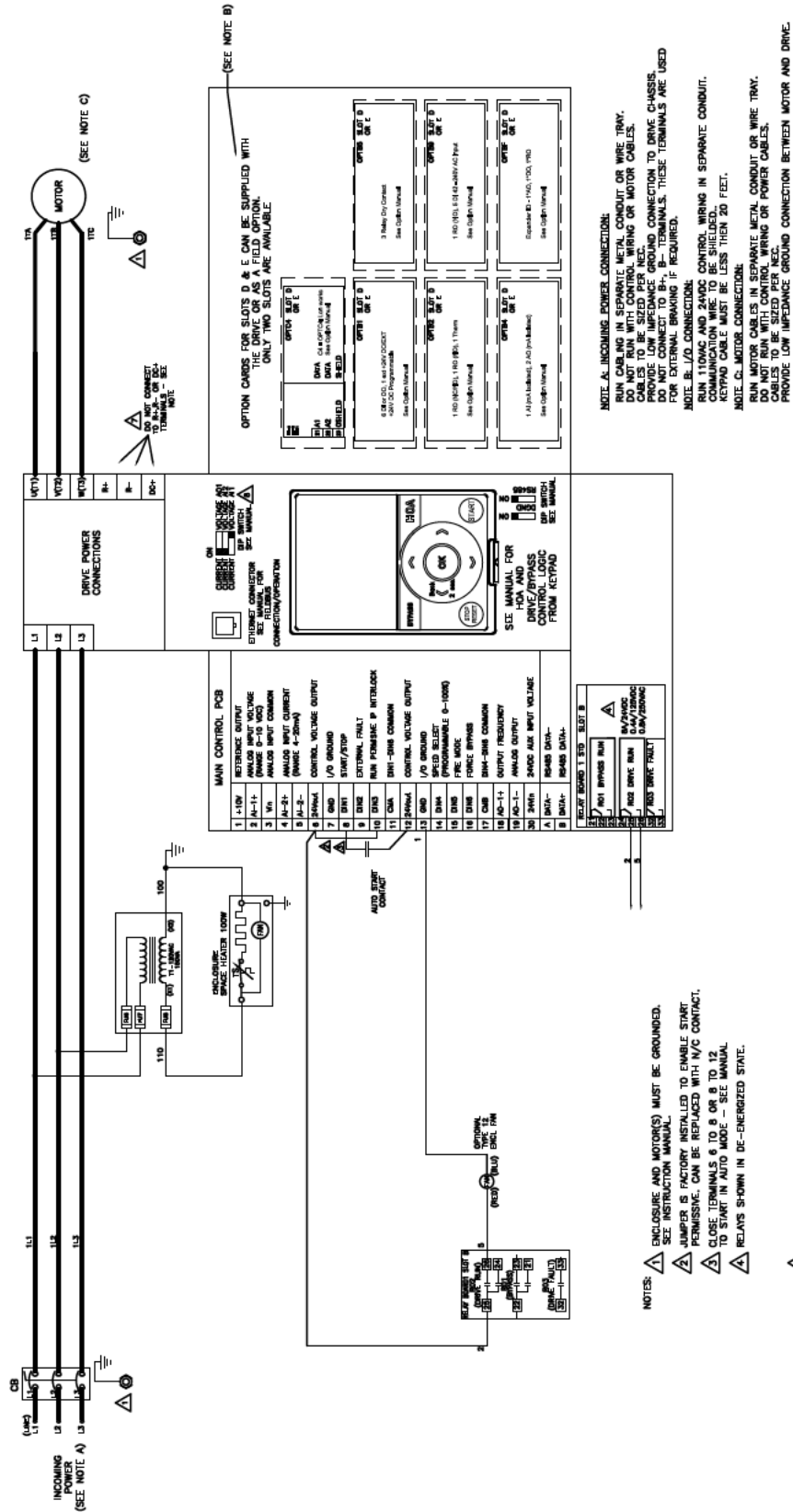

IntelliDisconnect with PE option Output Contactor and P3 option Isolation Fuses, (SA option shown)

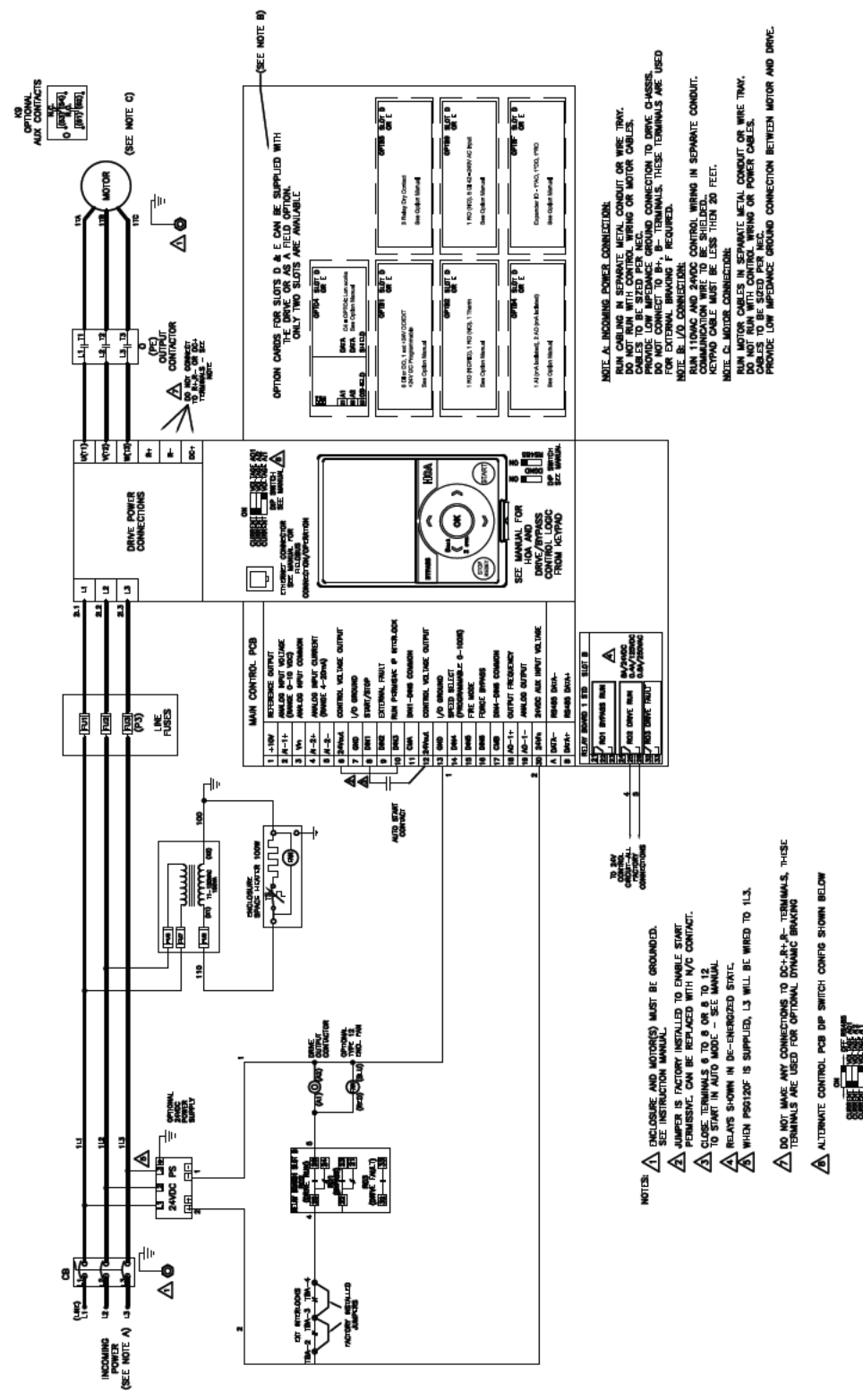

IntelliDisconnect with P3 option Isolation Fuses, (SA option shown)

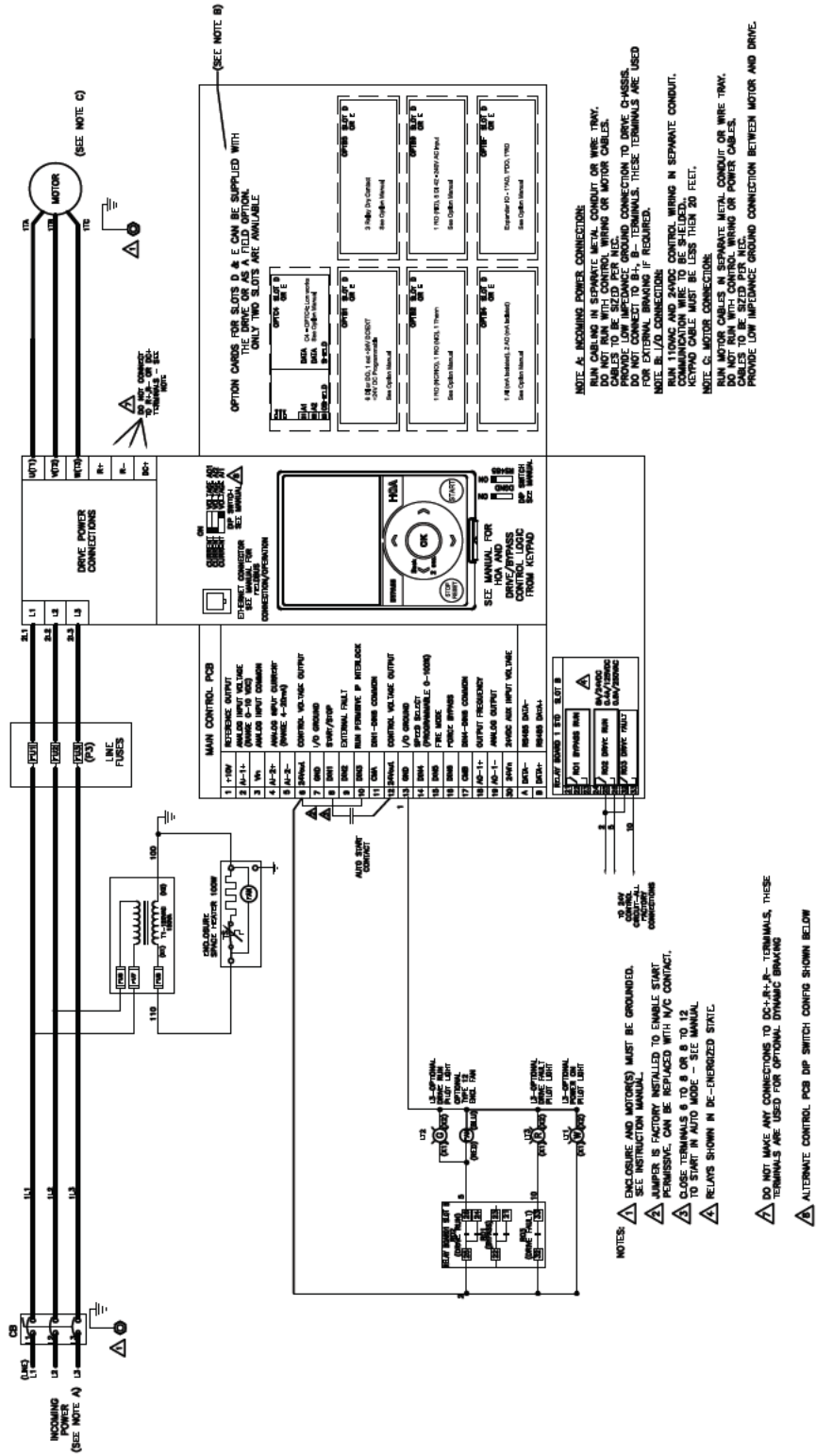

Conduit plates

Enclosure Standard Sizes 4-7 have removable top and bottom conduit plates to make wiring and conduit connections easier. See Dimension and Mounting section for access areas.



Wiring

Input Power wiring

Input power connection are made to the disconnect device. Input power connection points are identified by Label (L1, L2 and L3).

Typical Input Power Connection Point Labels



Connect Input Power Wires here

Both Intellidisconnect and Intellipass provide an input disconnect by using a UL Listed, Manual Self-protected Combination Motor Controllers (Type E), Model XTPR or a listed molded case circuit breaker, Models HFD sized as indicated in Input Wiring Table. Line Side Adapter (Eaton model XTPAXLSA or XTPAXLSAD) is also provided with the XTPR Type E devices.

These devices provide a disconnect function and the IntelliPass models branch protection/short circuit protection and Class 10 Motor overload protection while running in bypass. These devices are factory adjusted to the nameplate value of unit-See Input Wiring Table. If necessary adjust the dial for proper Motor FLA -see examples below.

If Necessary,
Set Motor FLA here
Value is Factory Set to Nameplate
Value
See Input Wiring Table

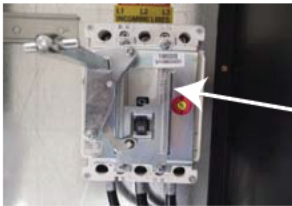

If Necessary, Remove Operator
Mechanism to Access Setting Dials
to set Motor FLA
Value is Factory Set to Nameplate
Value See Input Wiring Table



Input Wiring Details

Volts	Hp	Current	Eaton P/N Branch protection or Disconnect	FLA Adj Range	Instructions See Eaton.com	Eaton P/N LSA Adapter	Torque			Tool
							Wire range	lb-in	N-m	
208	1	4.6	XTPR6P3BC1	4-6.3	PUB51173 MN03402005e	XTPAXLSA				
	2	7.5	XTPR010BC1	6.3-11						
	3	10.6	XTPR012BC1	8-12						
230	1	4.2	XTPR6P3BC1	4-6.3			14-6	35	4	0.8 x 5.5 1 x 6 mm (flat) Size 2 pozidriv
	2	6.8	XTPR010BC1	6.3-11						
	3	9.6	XTPR012BC1	8-12						
480Y/277	1	2.1	XTPR2P5BC1	1.6-2.5						
	2	3.4	XTPR004BC1	2.5-4						
	3	4.8	XTPR6P3BC1	4-6.3						
	5	7.6	XTPR010BC1	6.3-11						
	7.5	11	XTPR012BC1	8-12						
208	5	16.7	XTPR025DC1	20-25	MN03402004e	XTPAXLSD				
	7.5	24.2	XTPR025DC1	20-25						
	10	30.8	XTPR032DC1	25-32						
230	5	15.2	XTPR016DC1	10-16						
	7.5	22	XTPR025DC1	16-25						
	10	28	XTPR032DC1	25-32						
480Y/277	10	14	XTPR016DC1	10-16			8-0	54	6	4mm Hexagon socket- head spanner
	15	21	XTPR025DC1	16-25						
	20	27	XTPR032DC1	25-32						
208	15	46.2	XTPR050DC1	40-50						
230	15	42	XTPR050DC1	40-50						
480Y/277	25	34	XTPR040DC1	32-40						
	30	40	XTPR050DC1	40-50						
	40	52	XTPR058DC1	50-58						

Wiring

Volts	Hp	Current	Eaton P/N Branch protection or Disconnect	FLA Adj Range	Instructions See Eaton.com	Eaton P/N LSA Adapter	Torque			Tool
							Wire range	lb-in	N-m	
208	20	59.4	HFDMP3080JL	40-80	IL29C115C	N/A	14-10	35	4	Slotted Head
	25	74.8	HFDMP3080JL	40-81						
	30	88	HFDMP3100JL	80-100						
230	20	54	HFDMP3080JL	40-80			8	40	4.5	
	25	68	HFDMP3080JL	40-80						
	30	80	HFDMP3100JL	80-100						
	40	104	HFDMP3160JL	100-160						
480	50	65	HFDMP3080JL	40-80			6-4	45	5.1	
	60	77	HFDMP3080JL	40-80						
	75	96	HFDMP3100JL	80-100						

HFDMP FLA DIAL setting

HFDMP	A	B	C	D	E
80A	40	50	60	70	80
100A	80	*	90	*	100
160A	100	115	130	145	160

Motor Wiring

Motor connection points are identified by a label (1TA,1TB,1TC). See Output wiring table in technical section for wiring and torque information. Also see H-Max Installation manual MN04008005E for more details on connections to drive output terminals when an output contactor is not supplied.

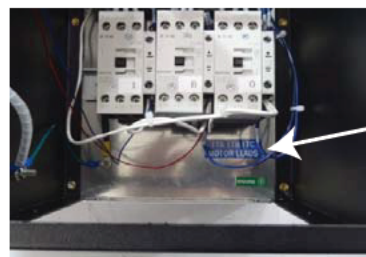

**Typical Motor
Connection
Point Label**

For IntelliPass models, wire the motor leads directly to the output contactor O. Motor connections are made directly to the bottom of the output contactor on the lower right side (see examples below)

Typical IntelliPass with 3 Contactors

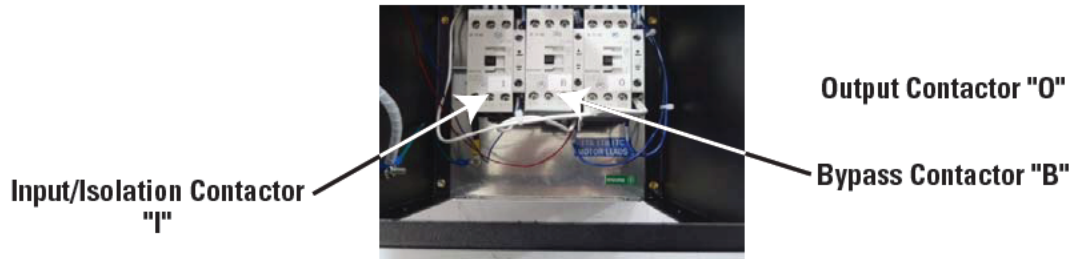

Typical IntelliPass with 2 Contactors

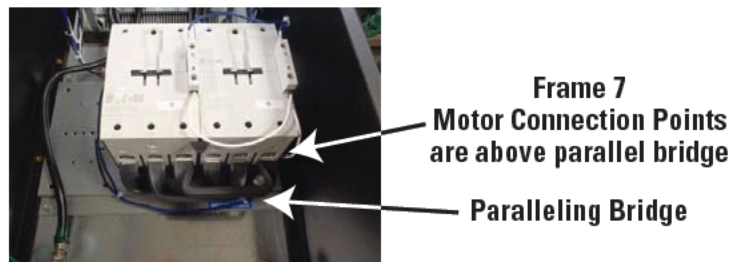
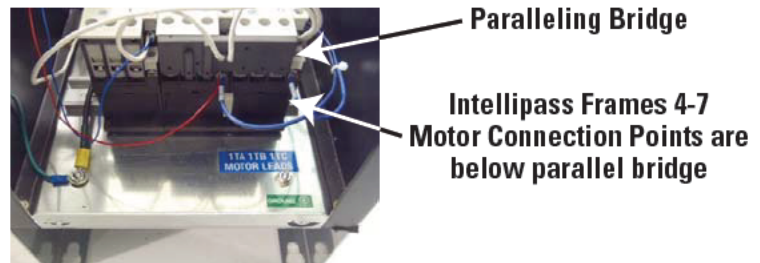
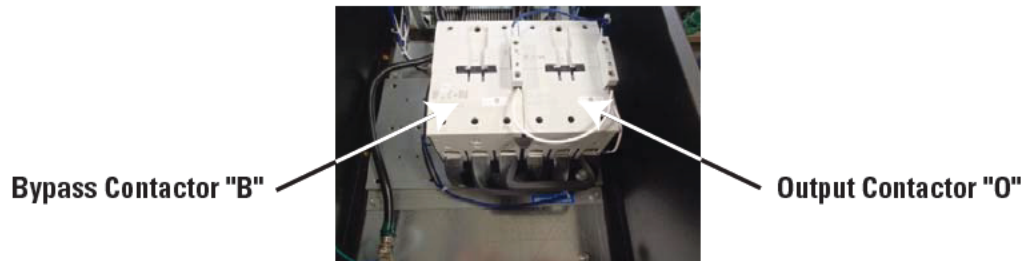

Wiring

For IntelliDisconnect models, wire directly to the drive output terminals or to the output contactor if the PE option is supplied.

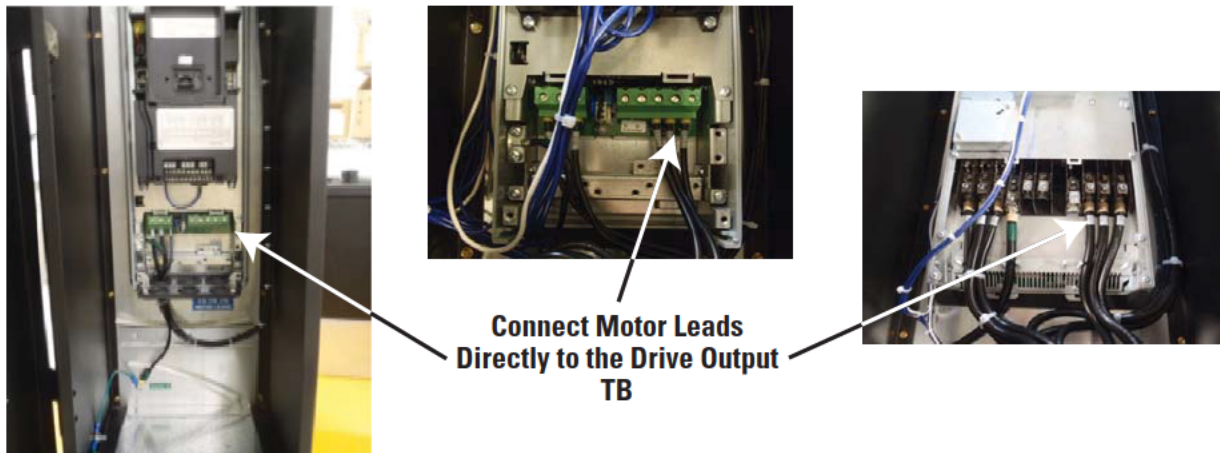
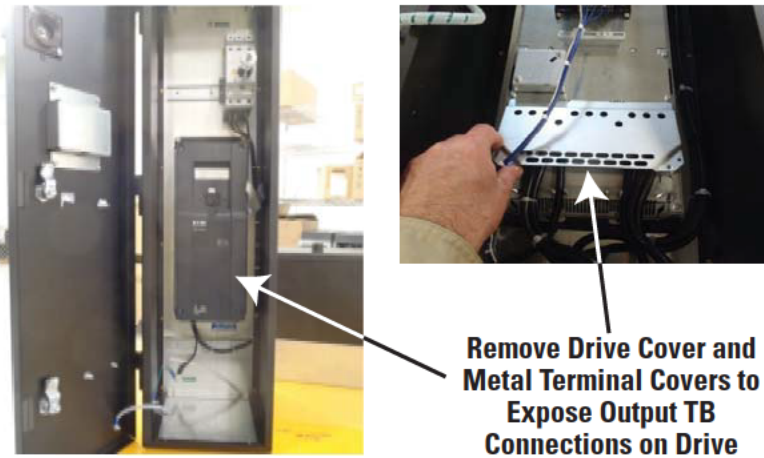

Output Wiring Details

Horse Power Rating			Contactor's Current Rating(Amps) {AC-1}	Eaton Contactor P/N	Instructions See Eaton.com	Wire range see note	Torque		Tool
208 V	230 V	460 V					lb.-in	N-m	
1, 2, 3	1, 2, 3	1,2,3, 5, 7.5,	22	XTCE007B	pub51210 IL03407014Z	18-14 single/ double	11	1.2	0.8 x 5.5 1 x 6 mm (flat) Size 2 pozidriv
5, 7.5, 10	5, 7.5, 10	10, 15, 20	40	XTCE018C	pub51232 pub51211 IL03407014Z	14-8 single/ double	28	3.2	0.8 x 5.5 1 x 6 mm (flat) Size 2 pozidriv
15, 20	15, 20	25, 30,40	60	XTCE040D	pub51216 IL03407033Z	14-1 single 12-2 dual	29.2	3.3	0.8 x 5.5 1 x 6 mm (flat) Size 2 pozidriv
-	-	50	98	XTCE065D					
25, 30	25, 30	60	110	XTCE080F	pub51188 IL03407039Z	8-3/0 single 8- 2/0 double	124	14	5mm Hexagon socket-head
-	40	75	160	XTCE115G					

Note: For IntelliPass models two wires per terminal is not allowed because the factory installed paralleling bridge uses one connection point

Ground Wiring

Both input and output ground studs are provided and marked with label. Hardware is also supplied.

Typical Ground Stud and Labels

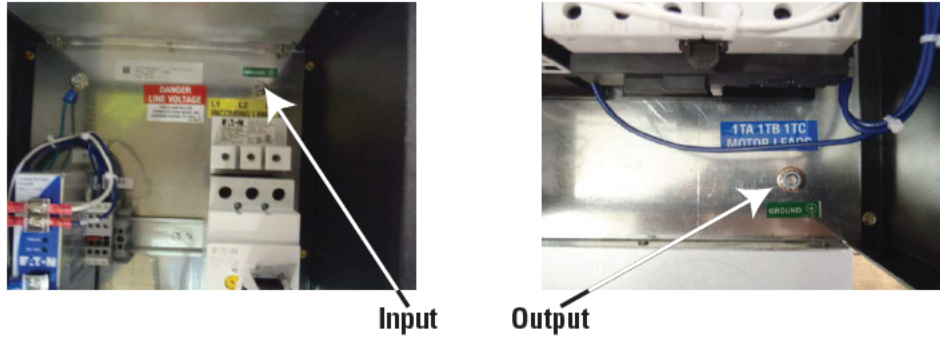

Frames 4 thru 6 have 10-32 studs on the back panel, and the supplied nut, flat washer and lock washer should be torqued to 30 lb-in

Frame 7 has 1/4-20 studs on the back panel, and the supplied nut, flat washer and lock washer should be torqued to 65 lb-in

Control Wiring

No additional control wiring is necessary for basic operation - see schematic for Auto Start contact, Auto reference connections and interlock connections to control PCB terminal block if required.

See H-Max Installation manual MN04008005E for more information on control wiring and control board layout and connections.

For ease of access the control terminals blocks can be unplugged for wiring.

All control I/O wiring must be segregated from line (mains) and motor cabling.

Run 120 Vac and +24 Vdc control I/O in separate conduit if applicable.

Control I/O terminals must be tightened to 4.5 lb (0.5 Nm).

In addition, the IntelliPass models provide an additional "External Interlock" input on TBA 2 & 3. This can be used to remove the 24V power from the contactors and door control elements. If is factory jumpered. If removed, it removes 24V power to the bypass and drive contactors. It does not disable the drive from running, only from being connected to a motor. Under some circumstances the drive/bypass could still be commanded to run but since the contactors are disabled, the motor will not run, however the drive keypad may indicate it is running. Refer to the schematic

This external interlock input is not supplied on the IntelliDisconnect models unless the output contactor with power supply option is supplied. Refer to the schematic.

Typical TBA Interlock

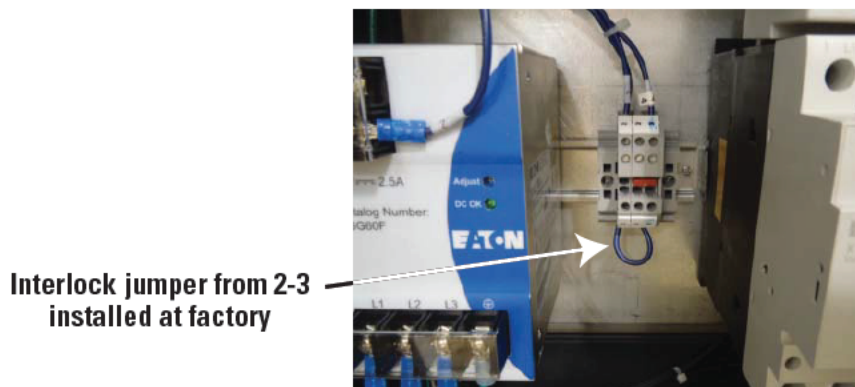

Initial Power up - IntelliPass and IntelliDisconnect

Initial Power up - IntelliPass and IntelliDisconnect

When the IntelliPass or IntelliDisconnect is first powered up, the startup wizard command should be displayed.



Follow the Quick Setup guide MN040008004E to set up Drive for your specific application with the following exceptions:

When the **Bypass screen appears** set it to "Enabled" for IntelliPass and "Disabled" for IntelliDisconnect Models

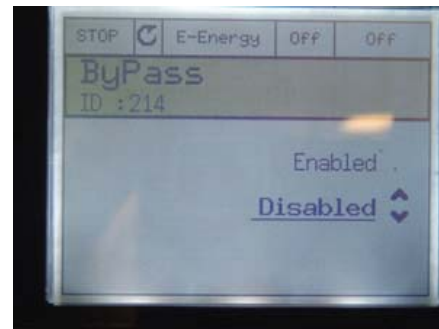

IntelliDisconnect Operation (starting/stopping of the motor)

IntelliDisconnect operation is the identical to a standard H-Max open Drive. The only difference is that an input disconnect is provided. For more information on Speed control and other Drive features see Application Manual MN04008006E. See option sections for more information on operation of IntelliDisconnect options i.e. Drive output contactor.

IntelliPass Operation (starting/stopping of the motor)

The IntelliPass operation is similar to the IntelliDisconnect but has the added feature of a built in Drive Bypass. This section gives basic information on operations for controlling the starting and stopping of the motor in both the Drive and Bypass modes. For more information on Speed control and other Drive features see Application Manual MN04008006E

The IntelliPass has 2 modes:

Drive mode (normal VFD operation),

Bypass mode (across the line).

The mode is selected via the Keypad. The actual starting and stopping of the motor is determined by the HOA selection and the Control Place selections. The Control place is defined as the location from where the Drive is started and stopped. The control place can be: Keypad start button, I/O contacts wired to the logic terminal blocks, Fieldbus control or PC. See Quick Start Guide MN04008005E or Application Manual MN04008006E for more information.

The only exception is if the M1 Manual Bypass option is supplied, this option can override the Drive logic and can start the motor in Bypass immediately.

Drive Mode

When the IntelliPass is in the Drive mode, the text “E-Energy” is shown on status bar. (If E-Energy function is not active the text “Ready” will be shown)

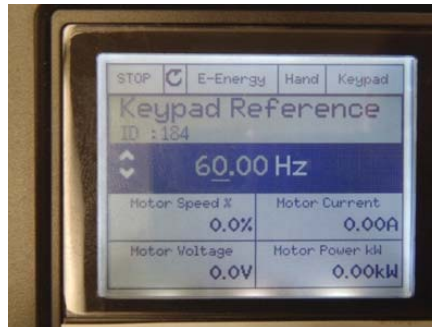

When the system is first commanded to run, the output contactor O is energized and the motor is connected to the Drive. The “O” contactor is controlled by the IntelliPass logic via Relay 2 output. The speed of the motor is determined by the speed set point of the H-Max Drive. When the H-Max is commanded to stop, the Drive will reduce the speed of the motor and when the motor speed reaches zero, the output contactor “O” is de-energized and the motor is disconnected from the IntelliPass. The output contactor also opens immediately if there is a Drive fault. (See Schematic)

The IntelliPass system is also interlocked. When the output contactor “O” is energized, the Bypass contactor “B” is prevented from being energized by electrical interlocks in each contactor coil control circuit and a logic interlock built in to the IntelliPass software. (See Schematic)

Bypass Mode

When the IntelliPass is in the Bypass mode, the text “Bypass” is shown on status bar.

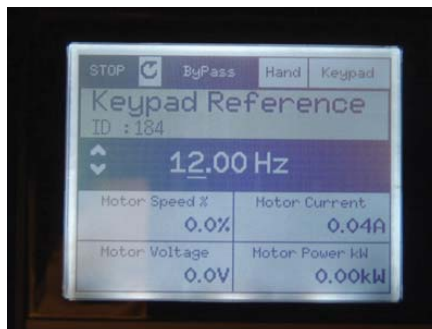

When the system is commanded to run in the Bypass mode, the motor is connected to the line through the Bypass contactor (B). The B contactor is controlled by the Drive logic via a Relay 1 output.

The Bypass mode can be selected in 3 ways:

- Manually via the Drive logic controls (i.e. Keypad, Fieldbus or I/O).
- Automatically after a Drive fault - if the Auto Bypass feature is active.
- Manually by a door switch (Option) - Manually using the manual Bypass switch as part of the option M1.

Manual Bypass

Manual Bypass can be activated either by using the Bypass button on the keypad, by using a digital input on the control TB or from the Fieldbus. The user can toggle between Bypass and Drive modes by pressing the keypad Bypass button or the TB inputs. Once in the Bypass mode, the start command can be given through any control place (I/O, Keypad, and Fieldbus) in the same manner as starting in the Drive mode.

IntelliPass Operation (starting/stopping of the motor)

Using the keypad to select Bypass Mode:

When the Bypass button is pressed, the following options are shown to the user. Select the desired mode by using the arrow keys and pressing the OK key.



The user can toggle between modes by pressing the Bypass button again. If Bypass button is pressed while the Drive is running, the keypads will display "Bypass is not allowed". The system must be stopped to allow a change from Drive to Bypass mode. Likewise if the system is running in Bypass and the Bypass key is pressed the display will indicated "Motor Running in Bypass". To change state back to Drive the system must be stopped. The keypad will display Bypass in the Status display when in the Bypass mode and Ready or E-Energy when in the Drive mode

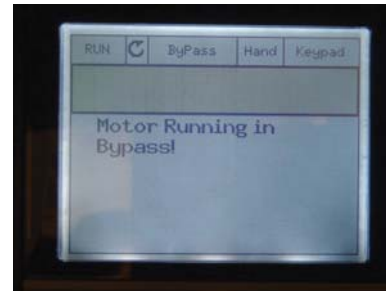
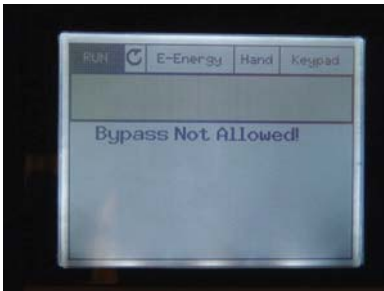

Using the digital input to select Bypass Mode:

If the digital input (Force Bypass) is used to select the Bypass mode, the Drive is set to the Bypass mode the next time the unit is stopped. If the command is given while the unit is running in the Drive mode, there is no effect until the stop command is given and the Drive reaches zero speed. Once the Drive stops, the Bypass mode is active and the keypad will display the Bypass mode. The Bypass and motor will start when a valid start command is received. Note that the Force Bypass function is the factory default for Digital Input #6 P2.3.6.2 located at TB16 on the control module and is also factory wired to the M1 Manual Bypass option if supplied.

Using the Fieldbus to select Bypass Mode:

The Fieldbus command works the same as the digital input.

Auto Bypass operation

The Drive can also be Bypassed automatically if certain faults occur. When the selected fault occurs, the Drive is first stopped. Then, depending on the Automatic Reset parameter, the Drive is either Bypassed instantly or the fault is first tried to reset. If the reset fails, the motor is automatically started in Bypass.



When the Drive goes to Auto Bypass, the keypad displays "Going into AutoBypass" for 10 seconds. After the delay, the Drive goes to the Bypass mode and starts the motor (the run command must still be present).

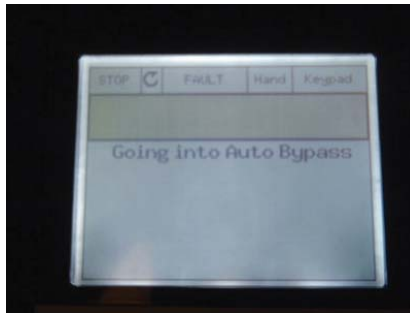

When the fault condition is not active, the Drive is set back to Drive mode automatically and the Bypass running signal is reset. The Drive returns to the normal operation.

Automatic Reset selections

- 0 = Not used
- 1 = Auto Bypass (Visible only if Bypass is enabled)
- 2 = Reset faults
- 3 = Reset/Bypass (Visible only if Bypass is enabled)

Activate the Automatic Reset functions with this parameter.

For option 1, if the Drive faults, the Drive switches automatically to Bypass and leaves the fault active on the Drive. For option 3, the Drive will first try to auto reset the faults but if not successful, it will then switch to Bypass. Option 2 just tries to reset the fault without going into Bypass. See the application manual for more information on Auto reset operation.

Manual Bypass (forced) - M1 option

The IntelliPass also has a forced manual Bypass option. This is controlled by a door mounted Drive/Off /Bypass switch. The door switch will start the motor in Bypass immediately regardless of Drive logic or state. This switch manually overrides the system (keypad) and forces the unit into Bypass mode even if the Drive is in operative or removed from the system - See schematic and the factory wired option section for more information.

HOA Control- IntelliPass

The Keypad HOA button is used for fast and easy changing between Hand, Off and Auto control places the change the speed set point source. HOA Control works in both the Drive and Bypass modes of operation. However speed set point has no functions when in Bypass since the motor runs full speed across the line.



Control place is defined as the location from where the Drive or Bypass is started and stopped. Hand and Auto are two different control places.

There are four parameters for selecting a control source and reference source for them: P2.1.3 HOA Control Source, P2.1.4 Start Source Hand, P2.1.5 Speed Set point Hand, P2.1.6 Start Source Auto & P2.1.7 Speed Set point Auto. The Start Source selections are: Keypad, I/O Terminal, I/O 3-wire & Fieldbus Ctrl. For the Drive mode, the Speed set point the selections are: Keypad Ref, Fieldbus, AI1, AI2, AI1+AI2, & PID1 (if PID is activated). See Quick Start Guide MN04008005E or Application Manual MN04008006E for more information.

IntelliPass/IntelliDisconnect Technical information

When control place Off is selected, the Drive cannot be started anywhere. It prohibits the start command for both Drive and Bypass. If the M1 option is supplied, the Bypass may force started in the HOA off mode by using the Door switch.



Key Parameters related to proper IntelliPass Bypass operation

The following parameters are related to Bypass functionality and are factory default set. Changing them will affect proper IntelliPass operation.

P2.1.2 Bypass: This parameter is for activating the Bypass functionality. It is factory enabled. If disabled the Bypass keypad button is inactive and some parameters may be hidden. This is part of the Start-up wizard

P2.3.2.2.1 (RO1 Function) set to Bypass Run. This signal is active if the Bypass mode has been selected and the run command is active - this relay output controls the Bypass contactor it should not be changed.

P2.3.2.2.5 (RO2 Function) set to Run. This signal is active if the Drive mode has been selected and the run command is active - this relay output controls the output contactor if should not be changed

P (DI2 Function) - (DI6 Function): set to Force Bypass.

If Force Bypass option has been selected for digital input and the input is activated, the Drive goes to Bypass the next time it is started. If the M1 option is supplied, this input should not be changed.

IntelliPass/IntelliDisconnect Technical information

See H-Max Installation manual MN04008005E for additional data

Enclosure: Type 1 or Type 3R as ordered

Max Ambient Temp: 40° C

Wire temperature rating of field installed conductors: Use 75° C copper conductors only

IntelliPass™ Short Circuit Rating

Frame	Voltage	Available current
4-6	240 Vac, 480Y/277 Vac	65,000 A
7	480 Vac	65,000 A

IntellidDisconnect™ Short Circuit Rating

Frame	Voltage	Available current	Breaker/Disconnect
4-6	240 Vac, 480Y/277 Vac	65,000 A	MMP
7	480 Vac	65,000 A	HFDMP

H-Max Installation Manual Addendum

New control board update for 230V, 480V & 575V

525-600V offering update

Effective February 2017



EATON

Powering Business Worldwide

Disclaimer of Warranties and Limitation of Liability

The information, recommendations, descriptions, and safety notations in this document are based on Eaton Electrical Inc. and/or Eaton Corporation's ("Eaton") experience and judgment, and may not cover all contingencies. If further information is required, an Eaton sales office should be consulted.

Sale of the product shown in this literature is subject to the terms and conditions outlined in appropriate Eaton selling policies or other contractual agreement between Eaton and the purchaser.

THERE ARE NO UNDERSTANDINGS, AGREEMENTS, WARRANTIES, EXPRESSED OR IMPLIED, INCLUDING WARRANTIES OF FITNESS FOR A PARTICULAR PURPOSE OR MERCHANTABILITY, OTHER THAN THOSE SPECIFICALLY SET OUT IN ANY EXISTING CONTRACT BETWEEN THE PARTIES. ANY SUCH CONTRACT STATES THE ENTIRE OBLIGATION OF EATON. THE CONTENTS OF THIS DOCUMENT SHALL NOT BECOME PART OF OR MODIFY ANY CONTRACT BETWEEN THE PARTIES. In no event will Eaton be responsible to the purchaser or user in contract, in tort (including negligence), strict liability or otherwise for any special, indirect, incidental, or consequential damage or loss whatsoever, including but not limited to damage or loss of use of equipment, plant or power system, cost of capital, loss of power, additional expenses in the use of existing power facilities, or claims against the purchaser or user by its customers resulting from the use of the information, recommendations, and descriptions contained herein.

The information contained in this manual is subject to change without notice.

Cover Photo: H-Max Series Drives

Table of Contents

Manual Addendum	4
New Control Board Installation Requirements	5
Control Board	5
LED Status Indication.....	6
Control Board Terminals	6
Control Wiring	6
DIP Switch Functionality	7
Digital input ground isolation.....	8
Field Bus Connection	8
Control Board Cabling.....	9
Battery for Real Time Clock	9
H-Max Series Overview - 525-600V	10
Catalog Number Selection	10
Power Ratings and Product Selection	11
Mounting Drive Dimensions	12
H-Max Technical Data.....	13
Cable Power and Motor Wiring Guidelines	15

Manual Addendum

This manual is an addendum to the H-Max Installation Manual (MN04008005E). This addendum provides technical information and installation specific to the new control board that launched in March 2017 and the 525-600V offering added in October 2016. The manual MN04008005E covers the majority of installation requirements and recommendations. It is recommended that you use this addendum and the full Installation Manual MN04008005E for installing an H-Max product.

LED Status Indication

The status LED of the drive shows the status of the drive. The status LED is located in the control panel, below the keypad, and it can show 5 different statuses.

Color of the LED light	Status of the drive
Blinking slowly	Ready
Green	Run
Red	Fault
Orange	Alarm
Blinking fast	Downloading software

Control Board Terminals

Here is the basic description of the terminals of the standard I/O board.

Control Wiring

- All control I/O wiring must be segregated from line (mains) and motor cabling
- Control wiring shall be shielded twisted pairs. To meet EMC levels required by ENG1800-3 (2004). Control wiring must be Type 4 cable
- Run 120 Vac and +24 Vdc control I/O in separate conduit
- Control I/O terminals must be tightened to 4.5 lb (0.5 Nm)

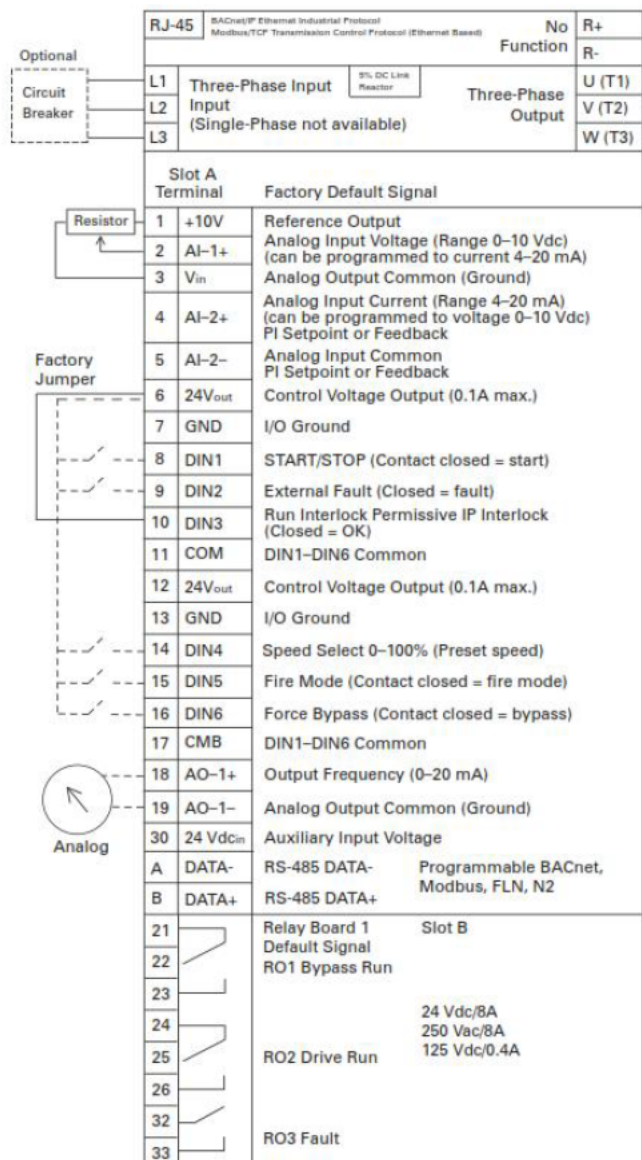

DIP Switch Functionality

You can make 2 selections with the DIP switches for specified terminals. The switches have 2 positions: up and down. You can see the location of the DIP switches and the possible selections below.

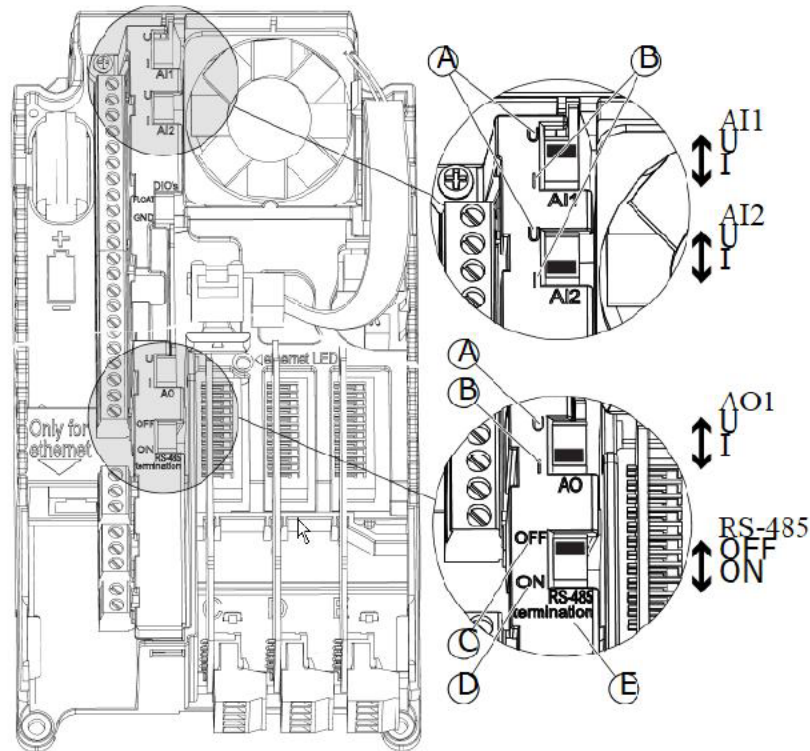

- A. The voltage signal (U), 0-10 V input
- B. The current signal (I), 0-20 mA input
- C. OFF
- D. ON
- E. The RS-485 bus termination

The DIP switch	The default position
AI1	I
AI2	I
AO1	I
RS485 bus termination	OFF

Digital input ground isolation

It is possible to isolate from ground the digital inputs (terminals 8-10 and 14-16) on the standard I/O board. To do this, change the position of a DIP switch on the control board.

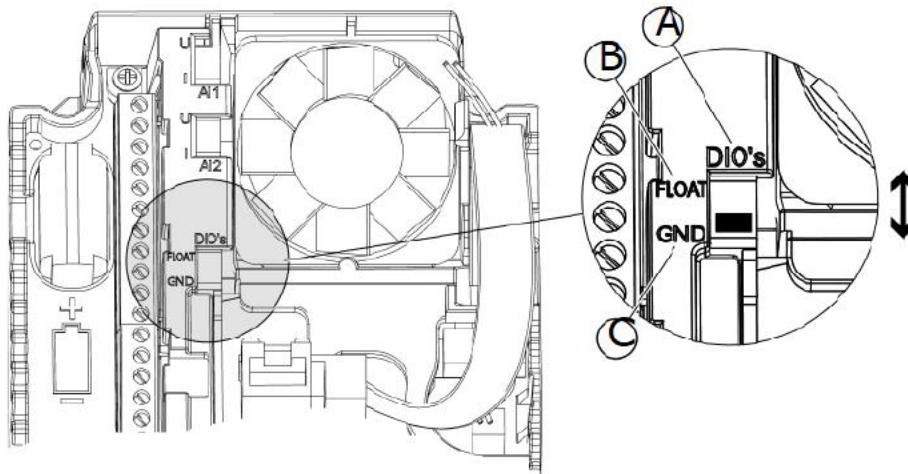

- A. The digital inputs
- B. Floating
- C. Connected to GND (default)

Field Bus Connection

You can connect the drive to fieldbus with an RS485 or an Ethernet cable. If you use an RS485 cable, connect it to terminal A and B of the standard I/O board. If you use an Ethernet cable, connect it to the Ethernet terminal below the cover of the drive.

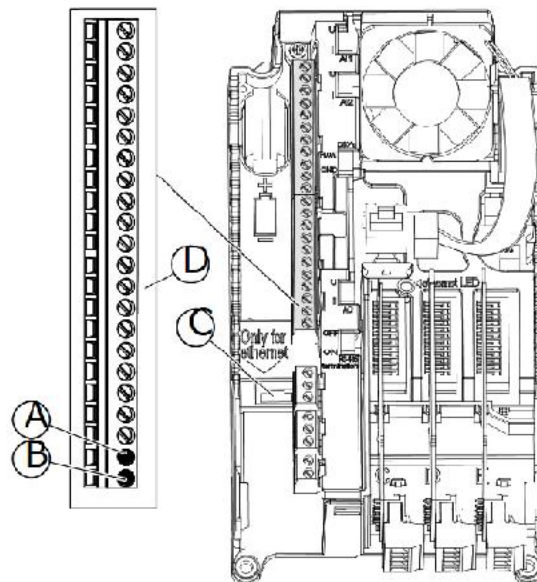

- A. RS485 terminal A = Data –
- B. RS485 terminal B = Data +
- C. The Ethernet terminal
- D. The control terminals

Control Board Cabling

The standard I/O board has 22 fixed control terminals and 8 relay board terminals.

Selection of the Control Cables

The control cables must be a minimum of 0.5 mm² screened multicore cables. The terminal wires must be a maximum of 2.5 mm² for the relay board terminals and other terminals.

The terminal	The terminal screw	The tightening torque	
		Nm	lb-in.
All the terminals of the I/O board and the relay board	M3	0.5	4.5

Battery for Real Time Clock

To use the Real Time Clock (RTC), you must install a battery in the drive.

1. Use a ½ AA battery with 3.6 V and a capacity of 1000-1200 mAh. You can use, for example, a Panasonic BR-1/2 AA or a Vitzrocell SB-AA02.
2. Install the battery on the left side of the control panel.

The battery will last approximately 10 years. See more about the functions of the RTC in the Application Manual.

H-Max Series Overview - 525-600V

Catalog Number Selection

H-MAX Series Open Drives

Notes

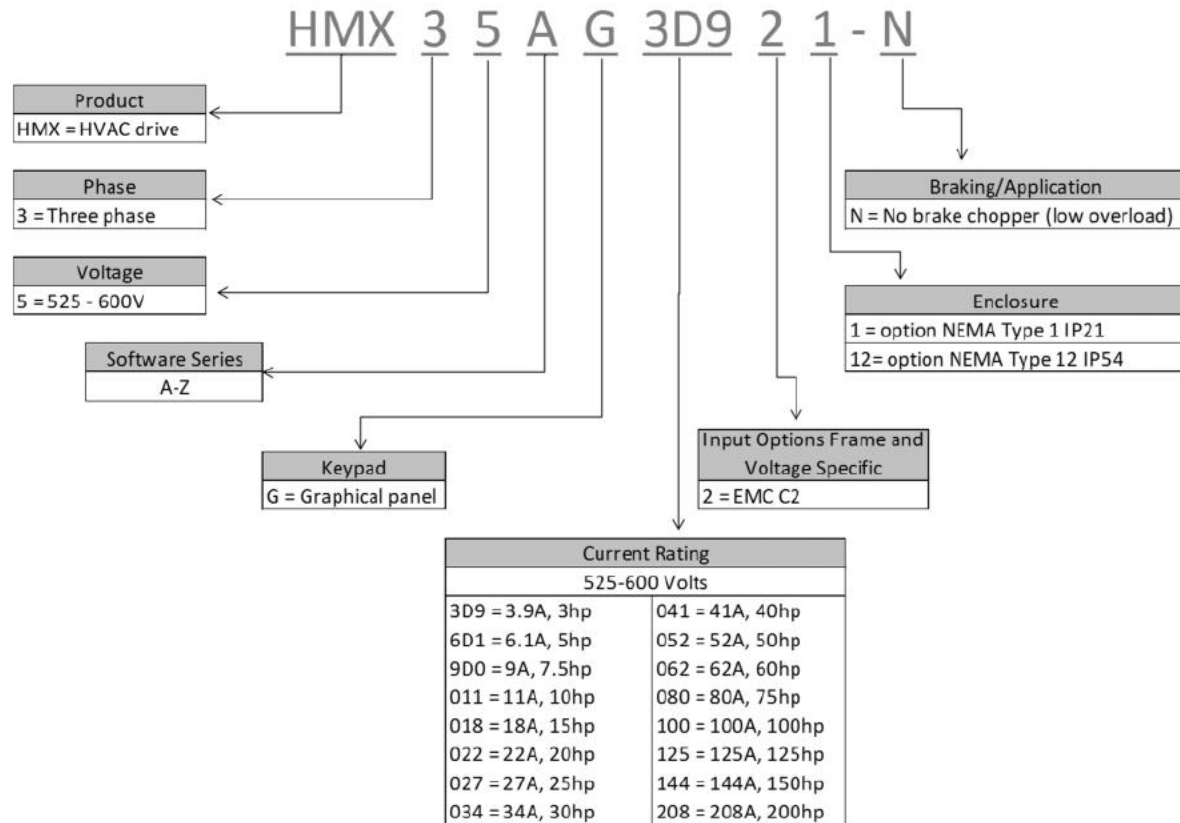

All boards are varnished (conformed coated). Corrosion resistant.
 Battery included in all drives for real-time clock. Three year lifetime.
 Keypad kit includes HOA bypass.
 Keypad kit includes HOA, back reset for Europe application.
 EMI/RFI filters included.
 DC link choke included.

Power Ratings and Product Selection

H-Max Series Drives – 525-600V

NEMA Type 1/IP21 or NEMA Type 12/IP54

Frame Size	Drive Rated Current and hp Drive Rating Low Overload Full		Drives Input Amps	De-Rated Low Overload Full Load Amps at 50°C	Can Be: 1 = N1 = IP21 2 = N12 = IP54 Catalog Number
	Load Amps at 40°C	600V 60Hz Horsepower			
FR5	3.9	3	4.6	3.3	HMX35AG3D92_-N
	6.1	5	6.8	5.2	HMX35AG6D12_-N
	9	7.5	9	7.7	HMX35AG9D02_-N
	11	10	10.5	9.4	HMX35AG0112_-N
FR6	18	15	19.9	15	HMX35AG0182_-N
	22	20	23.3	18	HMX35AG0222_-N
	27	25	27.2	23	HMX35AG0272_-N
	34	30	32.8	28	HMX35AG0342_-N
FR7	41	40	45.3	34	HMX35AG0412_-N
	52	50	53.8	44	HMX35AG0522_-N
	62	60	62.2	52	HMX35AG0622_-N
FR8	80	75	90	68	HMX35AG0802_-N
	100	100	106	85	HMX35AG1002_-N
	125	125	127	106	HMX35AG1252_-N
FR9	144	150	156	122	HMX35AG1442_-N
	208	200	212	176	HMX35AG2082_-N

Mounting Drive Dimensions

NEMA Type 1/12 Open Drives (1-200hp)
 Approximate Dimensions in Inches (mm)

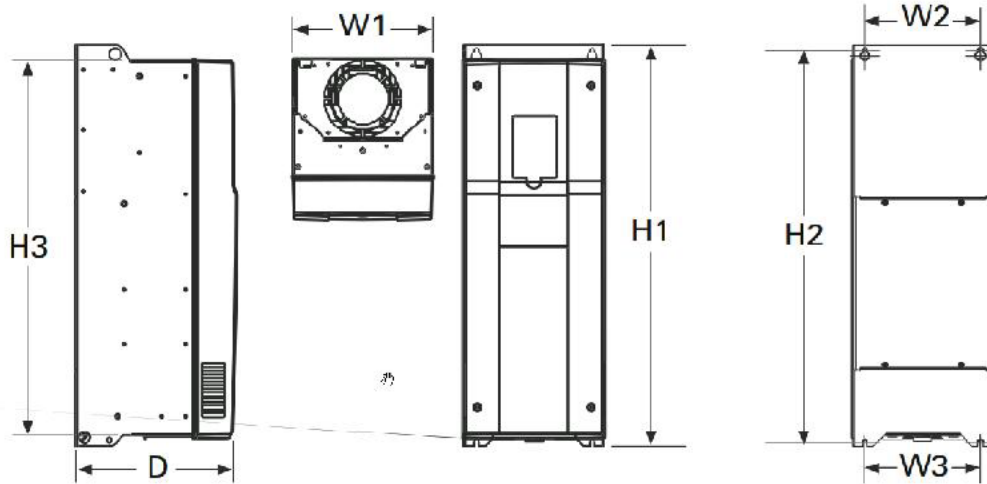

Frame Size	Line Voltage	hp (VT)	Amperes	D	H1	H2	H3	W1	W2	W3	Weight in Lbs
FS5	600 Vac	3-10	3.9-11	8.73	16.5	15.98	15.04	5.67	4.53	3.94	22
FS6	600 Vac	15-30	18-34	9.29	21.93	21.28	20.24	7.68	5.83	5.83	44.1
FS7	600 Vac	40-60	41-62	10.49	25.98	25.39	24.29	9.06	7.48	7.48	82.6
FS8	600 Vac	75-125	80-125	13.76	38.02	37.26	37.26	11.42	9.29	1.42	154.3
FS9	600 Vac	150-200	144-208	14.63	22.09	31.89	31.89	18.9	15.75	1.57	238.1

H-Max Technical Data

Attribute	Description	Specification	
Mains connection	Input voltage U_{in}	525-600V, -10 to 10%	
	Input frequency	50-60 Hz, -5 to 10%	
	Connection to mains	Once per minute or less	
	Starting delay	6s (FS5 to FS6); 8s (FS7 to FS9)	
Motor connection	Output voltage	0- U_{in}	
	Continuous output current	I_L : Ambient temperature maximum 40°C, up to 50°C with derating, overload 1.1 x I_L (1min./10 mins)	
	Output frequency	0-320 Hz	
Control characteristics	Frequency resolution	0.01 Hz	
	Switching frequency	FS5-FS9: 1.5-6 kHz Default: 2 kHz For a product that is configured for a C4 installation on IT network the maximum switching frequency is limited to default 2kHz. Automatic switching frequency derating in case of overload.	
	Frequency reference		
	Analog input	Resolution 0.1% (10-bit), accuracy +1%	
	Panel reference	Resolution 0.01 Hz	
	Field weakening point	8-320 Hz	
	Acceleration	0.1-3000 sec.	
	Deceleration	0.1-3000 sec.	
	Ambient conditions	Ambient operating temperature	I_L : -10°C (no frost) to 40°C, up to 50°C with derating
		Storage temperature	-40° to 70°C
Relative humidity		0-95% R_H , non-condensing, non-corrosive	
Air quality:		Tested according to IEC 60068-2-60 Test Ke: Flowing mixed gas corrosion test, Method 1 (H ₂ S [hydrogen sulfide] and SO ₂ [sulfur dioxide]) Designed according to: IEC 60721-3-3, unit in operation, class 3C2 IEC 60721-3-3, unit in operation, class 3S2	
- Chemical vapors			
- Mechanical particles			
Altitude		100% load capacity (no derating) up to 1000m 1% derating for each 100m above 1000m Max. altitudes: 525-600V: 2000m (TN and IT systems, no corner grounding) Voltage for I/O signals: Up to 2000m: Allowed up to 240V 2000-4500m: Allowed up to 120V	
Vibration:		5-150 Hz	
- EN61800-5-1		Displacement amplitude: 1 mm (peak) at 5-15.8 Hz (FS4-FS9)	
- EN60668-2-6		Maximum acceleration amplitude: 1g at 15.8-150 Hz (FS4-FS9)	
Shock:			
- EN61800-5-1	UPS drop test (for applicable UPS weights)		
- EN60068-2-27	Storage and shipping: Maximum 15g, 11 ms (in package)		
Enclosure class	IP21/Type 1 standard in entire kW/hp range IP54/Type 12 option Note: Keypad required for IP54/Type12		

H-Max Technical Data, continued

Attribute	Description	Specification
EMC (at default settings)	Immunity	Fulfils EN61800-3 (2004), first and second environment EN61800-3 (2004), Category C3
	Emissions	The drive can be modified for IT-networks
Noise level	Average noise level (cooling fan) sound power level in dB (A)	FS5: 65 FS8: 73 FS6: 72 FS9: 75 FS7: 73
Safety	-	EN61800-5-1 (2007), CE, cUL (see nameplate for more detailed approvals)
Protections	Overvoltage trip limit	600V drives: 1094Vdc
	Undervoltage trip limit	Depends on supply voltage (0,8775*supply voltage): Supply voltage 600V: Trip limit 527V
	Eart fault protection	Yes
	Mains supervision	Yes
	Motor phase supervision	Yes
	Overcurrent protection	Yes
	Unit overtemperature protection	Yes
	Motor overload protection	Yes
	Motor stall protection	Yes
	Motor underload protection	Yes
	Short-circuit protection of 24V and 10V reference voltage	Yes

Cable Power and Motor Wiring Guidelines

Frame	Amp Suffix	hp	VFD	VFD	Fuse Rating (Class T)	NEC Wire Size (AWG)		Terminal Connection Size (AWG)	
			I(L) Amps at 40°C	I(L) Amps at 50°C		Line and Motor	Ground	Line and Mo- tor	Ground
FR5	3D9	3	3.9	3.3	6	14	12	20-5	17-8
	6D1	5	6.1	5.2	10	14	12	20-5	17-8
	009	7.5	9	7.7	10	14	10	20-5	17-8
	011	10	11	9.4	15	14	8	20-5	17-8
FR6	018	15	18	15	20	10	8	13-0	13-2
	022	20	22	18	25	10	8	13-0	13-2
	027	25	27	23	30	8	8	13-0	13-2
	034	30	34	28	40	8	6	13-0	13-2
FR7	041	40	41	34	50	6	6	9-2/0	9-2/0
	052	50	52	44	60	6	6	9-2/0	9-2/0
	062	60	62	52	70	4	4	9-2/0	9-2/0
FR8	080	75	80	68	90	1/0	2	1 AWG -350 kcmil	1 AWG -350 kcmil
	100	100	100	85	110	1/0	0	1 AWG -350 kcmil	1 AWG -350 kcmil
	125	125	125	106	150	2/0	2/0	1 AWG -350 kcmil	1 AWG -350 kcmil
FR9	144	150	144	122	175	3/0	3/0	1 AWG -350 kcmil	1 AWG -350 kcmil
	208	200	208	176	250	300 kcmil	300	1 AWG -350 kcmil	1 AWG -350 kcmil



DP001892C